

A PROGRAM OF IBHS

FORTIFIED

HOME

TM

HIGH WIND STANDARDS



2015

Table of Contents

Program Overview and Definitions	4
Goals.....	4
FORTIFIED Home™ Eligible Dwellings.....	4
Available Designations	4
Objectives.....	5
Designation Term Limit	6
Definitions	6
Bronze Designation Requirements	10
General Requirements	10
Existing Roof Designation	10
New Roof Designation	11
Detailed Requirements.....	11
Existing Roof Designation	11
Roof Deck Attachment.....	11
Prune trees to reduce risk of trees falling on house.....	14
Requirements	14
New Roof Designation	14
Addressing deteriorated or damaged roof decking or lumber on an existing home.....	14
Requirements	14
Deteriorated or damaged wood roof framing member(s)	16
Requirements	16
Strengthening of roof sheathing attachment	18
Re-nailing the roof decking	18
<i>Sawn Lumber or Wood Board Roof Decking: Existing Roof</i>	18
<i>Structural Wood Panel (Plywood or Oriented Strand Board-OSB) Roof Sheathing</i>	18
Existing Roof (re-nailing the roof decking).....	19
New Roof (attaching the roof deck).....	21
Sealing the roof deck	22
Options for shingle or metal roofs	22
Options for concrete and clay tile roofs	25
Drip Edge Requirements.....	27
Flashing Requirements	28
Installing qualified roof covering (re-roof or new roof installation).....	28
Asphalt Shingles	28
<i>Wind Testing/Rating Standards</i>	28
<i>Shingle Attachment</i>	29
Clay and Concrete Roof Tiles.....	29
<i>Clay and Concrete Tile Wind Resistance Requirement</i>	29
Metal Panels.....	29
<i>Metal Roof Wind Resistance Requirement</i>	29
Other roof coverings	30
Prune trees to reduce risk of trees falling on house.....	30
Requirements	31

Silver Designation Requirements	32
General Requirements	32
Detailed Requirements.....	33
Strengthening Gables Over 4 Ft Tall	33
Gable End Wall Sheathing.....	33
Gable End Wall Bracing.....	33
Prescriptive Methods for Existing Homes.....	34
Securing Chimneys.....	35
Prescriptive Retrofit Measures	35
Engineering-Based Measures	37
Anchoring Attached Structures (Porches and Carports)	37
Existing Home	37
New Home	37
Prescriptive Porch/Carport Uplift Worksheet	41
Example Calculation and Observations	42
Connections Designed by an Engineer	43
Gold Designation Requirements	44
General Requirements	44
Continuous Load Path (CLP).....	44
Existing Home.....	44
New Home.....	45
<i>Prescriptive Measures for one-story or two-story buildings where the distance between shear walls is less than or equal to 2.5 times the building width.....</i>	<i>45</i>
Alternate Guidance for Wood Frame Construction	51
Garage Door Requirements	51
Design Pressure Rating Requirements.....	51
Existing Homes.....	52
Appendix A: Gable End Wall Bracing Retrofit	53
Introduction.....	53
Prescriptive Method.....	56
Section A101 General	56
Section A102 Definitions.....	56
Section A103 Materials Of Construction.....	57
Section A104 Retrofitting Gable End Walls.....	58
Appendix B: Design Wind Pressures for Garage Doors	82
Extras	84
Disclaimer	84
About FORTIFIED & IBHS	84

Program Overview and Definitions

Goals

This FORTIFIED Home™ standard addresses high winds (defined as locations where the design wind speed is equal to or less than 90 mph as determined in ASCE7-05, or 115 mph as determined in ASCE7-10). The primary goal is to strengthen homes to improve resistance to damage from severe thunderstorms, straight-line wind events, and high winds at the edges of tornadoes.

FORTIFIED Home™ Eligible Dwellings

To be eligible for a FORTIFIED Home™–High Wind Designation, a home must be a single-family detached home installed on a permanent foundation. New and existing homes may qualify.

The following is a list of property types that are eligible for a FORTIFIED Home™–High Wind Designation:

1. Single-family site-built homes
2. HUD Zone 2 & Zone 3 single-family manufactured homes installed on qualified permanent foundations
3. Factory-built modular homes installed on qualified permanent foundations
 - Note: To be eligible for FORTIFIED Home™–High Wind Gold designation, factory-built modular homes must be manufactured by a certified plant.

Available Designations

FORTIFIED Home™–High Wind Bronze – New Roof

FORTIFIED Home™–High Wind Bronze – Existing Roof

FORTIFIED Home™–High Wind Silver – New Roof

FORTIFIED Home™–High Wind Silver – Existing Roof

FORTIFIED Home™–High Wind Gold – New Roof

FORTIFIED Home™–High Wind Gold – Existing Roof

Objectives

Achieving a FORTIFIED Home™–High Wind Bronze Designation indicates the home has been built or retrofitted to minimize roof damage and associated property damage, disruption and loss from severe thunderstorms, straight-line wind events, and high winds at the edge of a weak tornado.

This risk reduction is accomplished by:

1. Improving the roof sheathing attachment (with or without re-roofing an existing home or installing a roof on a new home)
2. Sealing the roof deck
3. Applying or verifying a new home already has a high-wind rated roof covering
4. Pruning trees to reduce risk of tree-related damage to the home (new or existing home)

Achieving a FORTIFIED Home™–High Wind Silver Designation indicates the home has been built or retrofitted to minimize roof and attached structure damage and associated property damage, disruption and loss from severe thunderstorms, straight-line wind events, and high winds at the edge of a tornado.

This reduction in risk is accomplished by:

1. Completing all FORTIFIED Home™–High Wind Bronze Designation requirements
2. Bracing and anchoring gable ends, including assuring gable end walls are sheathed with wood structural panels or equivalent strength sheathing
3. Anchoring wood frame chimneys to the roof structure
4. Anchoring attached structures (porches and carports)

Achieving a FORTIFIED Home™–High Wind Gold Designation indicates the home has been built or retrofitted in a manner that minimizes property damage, disruption and loss expected during severe thunderstorms, straight-line wind events, and high-intensity winds (EF-1/weak EF-2) at the edge of a tornado.

This reduction in risk is accomplished by:

1. Completing all FORTIFIED Home™–High Wind Bronze and Silver Designation requirements

2. Developing a continuous load path from the roof to the foundation based on the following minimum design wind speeds and exposure classification: ASCE 7-05 design wind speed $V = 110$ mph and Exposure B; ASCE 7-10 design wind speed $V_{ult} = 140$ mph and Exposure B
3. Reinforcing or replacing garage doors to meet the design pressure for 110 mph 3-second gust (ASD) design wind loads for appropriate terrain exposure

Designation Term Limit

The FORTIFIED Home™—High Wind Bronze, Silver and Gold Designations are valid for 5 years. Designations expire on March 31 following the fifth anniversary of the awarding of the designation. Homes may be redesignated for an additional 5-year term by having a redesignation inspection. The redesignation inspection focuses on the roof covering and any substantive changes to systems covered under the FORTIFIED Home™ program. Homeowners will receive a notice when a redesignation is required.

Definitions

ASCE 7: refers to the American Society of Civil Engineers standard entitled “Minimum Design Loads for Buildings and Other Structures.” This document provides design wind speed maps and methods for calculating design wind loads that are the basis for wind load design requirements specified in most U.S. codes and standards.

Aspect ratio: the ratio between the length and width of a home determined by dividing the length by the width.

ASTM: American Society for Testing and Materials (ASTM) is a standards organization that publishes technical standards for a wide range of materials and products.

Bearing point: the top of a wall that provides vertical support for the structure above. For a roof structure support, this would be the top of the wall below.

Certified FORTIFIED Home™ Evaluator: an individual who has met the professional requirements for certification established by IBHS, and who has achieved a passing score on the FORTIFIED Home™ Evaluator certification exam.

Continuous load path (CLP): an engineering term that refers to a series of elements and connections that allow forces, such as those created by high-wind events, to pass from one part of a structure to another and ultimately to the foundation. These elements and connections allow the building to resist the forces created by high winds as a cohesive unit. Without a

continuous load path, there are “weak links” in a building’s structural system. These weak links are where failures are most likely to occur.

Damaged or deteriorated lumber: generally, lumber that is marked by one or more of the following characteristics: soft or spongy, swelling or buckling, delaminating (plywood), or crumbling and flaking of the wood.

Design wind speed: the wind speed used in the building code to establish wind forces (pressures) that a building or parts of a building must be capable of resisting, in accordance with code-accepted procedures.

Documentation: evidence that a specific requirement has been met, either in the form of a test report, manufacturer’s installation guidelines or product markings.

Enhanced Fujita Scale: a damage scale developed for rating the intensity of tornadoes and frequently used to estimate tornado and severe windstorm wind speeds.

Living area: conditioned space in a home that is protected from the elements by walls, windows, doors, and the roof structure.

Mean roof height (MRH): the average height of the roof, usually calculated as the average of the eave and ridge height of the roof.

Metal roof: a roof that has metal as a primary roof covering material.

Prescriptive retrofit measure: a detailed retrofit measure provided in this guide, which does not require analysis by an engineer. These measures can be used to strengthen a home, so that it meets one or more of the requirements provided in this guide.

Qualified roof cover: a roof that is not visibly damaged or deteriorated, has documentation indicating appropriate ratings for high wind and has at least 5 years of useful life remaining, as determined by inspection, is eligible for inclusion in High Wind Bronze Designation – Existing Roof. A Certified FORTIFIED Home™ Evaluator must inspect the roof to determine the condition and remaining useful life of the roof covering.

Qualified sealed roof deck (SRD): a roof deck where all vertical and horizontal seams in the deck material are sealed to prevent water intrusion in the event that the primary roof covering is damaged or removed. A sealed roof deck can be accomplished by using roofing underlayments that are designed to stay in place and keep water from entering the home if the primary roof covering is damaged or lost due to high winds. This type of underlayment is applied when re-roofing. If sealing the roof deck on the exterior surface of the roof deck is not required because the existing roof covering meets the FORTIFIED Home™ program requirements for a qualified

roof, qualified closed-cell foam may be used to seal the deck on the interior (attic) surface. Attic access must be available to the entire underside of the roof deck.

Underlayments that may qualify as a sealed roof deck system for FORTIFIED Home™ designation purposes include:

- A peel-and-stick membrane applied over the entire roof deck
- A 4-in-wide peel-and-stick membrane tape applied over all joints in the roof deck, topped by roofing felt
- A properly attached synthetic underlayment with all seams taped or sealed
- 2 layers of ASTM D 226 Type II (#30) or ASTM D 4869 Type IV (#30) felt paper, lapped 19 in. on horizontal seams (36-in-wide roll), and 6 in. on vertical seams and fastened according to approved requirements

Roof framing member: the supporting framing member immediately beneath the roof deck, sloping from the ridge to the wall plate. This can be either an engineered truss or a stick-built rafter and joist system.

Roof ridge: the intersection of two roof planes at the peak of the roof.

Roof span: the maximum distance perpendicular to the ridge between outside bearing walls that provide vertical support for the roof structure. For relatively simple buildings, this is usually the maximum distance (perpendicular to the ridge) between the outer walls that run parallel to the roof ridge.

Scab: a flat piece of lumber that is attached to the side of an existing framing member or members to (a) splice a butt joint; (b) strengthen a damaged piece of wood; or (c) provide a better nailing surface for securing sheathing.

Shear walls: a wall or portion of a wall used to counter the effects of lateral load acting on a structure in a direction parallel to the wall (in-plane shear). Wind and earthquake loads are the most common loads that shear walls are designed to counteract.

Shingle roof: a roof that has asphalt shingles as a primary roof covering material.

Simple homes: rectangular homes, which have either a simple gable or hip roof shape and which do not have significant variations (more than 4-ft offsets) in the exterior wall lines.

Special Wind Regions: the basic wind speed to be used for design can be higher than reflected in ASCE 7-05 Figure 6-1 (ASCE 7-10 Figure 26.5-1) in mountainous terrain, gorges, and in those regions indicated on the ASCE maps as Special Wind Regions.

Terrain exposure category: Exposure category relates to the obstructions that surround a building and affect how wind interacts with the structure. There are 3 main categories:

- Exposure B—urban and suburban areas, wooded areas or other terrain with numerous closely spaced obstructions having the size of single-family dwellings or larger.
- Exposure C—open terrain with scattered obstructions, having heights generally less than 30 ft. This category includes flat open country and grasslands.
- Exposure D—flat, unobstructed areas exposed to wind flowing over open water for a distance of at least 1 mile. Shorelines in Exposure D include inland waterways, the Great Lakes and coastal areas.

Tile roof: a roof that has either concrete or clay tile as a primary roof covering material.

Underlayment: sheet-like material applied to the surface of the roof deck or roof sheathing prior to the installation of the primary roof covering material. This material usually provides a liquid water barrier over the roof sheathing that promotes runoff of water that penetrates the roof cover.

Wall openings: windows and all doors, including entry doors, sliding glass doors, and garage doors.

Bronze Designation Requirements

General Requirements

Existing Roof Designation

The FORTIFIED Home™–High Wind Bronze – Existing Roof provides prescriptive methods to create a qualified roof without requiring roof covering replacement on an existing home.

This approach may be used when roof covering replacement is determined to be unnecessary when ALL of the conditions listed below are met:

- Roof deck must be a minimum of $\frac{3}{8}$ -in. OSB or plywood for Bronze or Silver designation. For Gold designation, roof deck must be a minimum of $\frac{7}{16}$ -in. OSB or plywood.
- The existing roof cover is high-wind rated. Documentation is required and must include:
 - Name of the installer
 - Year of installation
 - Roof covering manufacturer
 - Product or model number
 - Wind or wind pressure rating (must match new roof requirements)
 - Impact rating (must match new roof requirements)
- The existing roof cover does not show visible signs of damage or deterioration.
- Only one layer of roof covering is present.
- The existing roof cover has at least 5 years of useful life remaining.
- There is adequate access to the attic to allow application of closed-cell spray urethane-based foam adhesives along joints between roof sheathing and roof framing members as well as along all seams between roof sheathing elements.

If the roof deck needs to be sealed and/or supplemental attachment is needed, the application of a closed-cell foam adhesive from inside the attic will be required. See Detailed Requirements below.

New Roof Designation

The FORTIFIED Home™–High Wind Bronze – New Roof provides prescriptive methods for installing a roof on a new home or re-roofing an existing home.

Re-roofing an existing home is required when one or more of the following conditions exists:

- The existing roof cover is NOT high-wind rated as described in the section below entitled “Installing qualified roof covering.”
- The existing roof cover shows visible abnormal signs of damage or deterioration.
- More than one layer of roof covering is present.
- The existing roof cover does not have least 5 years of useful life remaining.

When re-roofing, the following tasks will be required:

- Remove existing roof covering and underlayment.
- Inspect for damaged roof decking and/or roof framing and replace as necessary.
- Re-nail the roof deck (if current fastening is not in accordance with these standards).
- Seal the roof deck (if deck is not sealed with a qualified system).
- Install required drip edge, flashings and roof-mounted vents (if applicable).
- Install qualified roofing materials with appropriate high-wind rating and/or engineering.

Detailed Requirements

Existing Roof Designation

Roof Deck Attachment

If required, (see exemption at the end of this section) strengthening the attachment of roof sheathing and installation of a sealed roof deck system can be achieved by applying acceptable 2-part, spray polyurethane foam adhesive to the underside of the roof deck as shown in Figure 1.



Figure 1. Closed-cell polyurethane foam adhesive applied to the underside of the roof sheathing at the joints between the sheathing panels and along all intersections between roof sheathing and all roof framing members.

The minimum requirements for spray adhesives are:

- Product must be tested and evaluated in accordance with either ASTM E 330, Standard Test Method for Structural Performance of Exterior Windows, Doors, Skylights and Curtain Walls by Uniform Static Air Pressure (applied to roof sheathing), or TAS 202-94, Criteria for Testing Impact and Non-Impact Resistant Building Envelope Components Using Uniform Static Air Pressure. The minimum allowable Design Uplift Pressure must be greater than or equal to 80 psf and the proof test pressure achieved without failure or structural distress must be greater than or equal to 120 psf.
- Two-component spray polyurethane foam system with a minimum Core Density of 1.5–3.0 pcf in accordance with ASTM D1622, Standard Test Method for Apparent Density of Rigid Cellular Plastics.
- Spray polyurethane foam adhesive system must be installed by a properly trained and qualified applicator in accordance with the manufacturer’s maintenance and installation guidelines.
- Documentation from the installing contractor identifying the manufacturer and product used for the improved roof sheathing attachment/sealed roof deck must be provided to the Certified FORTIFIED Home™ Evaluator to be included with final designation

checklist. Documentation should also state that the installation meets the manufacturer's requirements for an allowable Design Uplift Pressure of at least 80 psf (proof test of at least 120 psf).

To provide enhanced roof sheathing attachment and to seal the roof deck, apply a 1.5- to 3-in. fillet of 2-part spray-applied polyurethane foam adhesive to:

- All joints between sheathing
- All intersections between roof sheathing and roof framing members
- All valleys

Use the minimum density and installation requirements prescribed by the manufacturer to meet a minimum Design Uplift Pressure of 80 psf on the sheathing.

Exception:

If it can be demonstrated through inspection and documentation that the roof sheathing attachment meets or exceeds minimum fastener size and spacing specified in Table 1 and Table 2, AND that a qualified sealed roof deck system is installed, then the installation of closed-cell foam is not required for the home to obtain the FORTIFIED Home™–High Wind Bronze – Existing Roof Designation.



Figure 2. Tree Damage

Prune trees to reduce risk of trees falling on house

Falling trees and limbs cause hundreds of millions of dollars of damage each year, as well as personal injuries and deaths. Windstorms and ice storms are leading causes of such damage and injuries.

Requirements

To mitigate potential damage from falling tree branches, removal of all tree branches that overhang the roof is required.

New Roof Designation

Addressing deteriorated or damaged roof decking or lumber on an existing home

On an existing home, deteriorated or damaged roof decking or lumber must be replaced prior to improving roof deck attachment.

Inspect the roof deck after the old roof covering materials have been removed to identify and replace any damaged or deteriorated decking (damage or deterioration could be from moisture, weathering, or insect infestation). Damaged or deteriorated decking would generally be marked by one or more of the following characteristics: soft or spongy wood, wood swelling or buckling, delaminating (plywood), or crumbling and flaking of the wood. Do not cut or notch supporting wood members when removing damaged/deteriorated decking. If the roof deck is damaged, there is a possibility that the wood roof framing members (rafters or truss top chords) below the damaged deck are damaged as well.

Requirements

- If a section of the roof deck is damaged or deteriorated, remove and replace the entire damaged sheet or board.
- Inspect the roof framing members below the removed decking. If more than ¼ in. of the surface is deteriorated or damaged, follow the Requirements for deteriorated or damaged wood roof framing members found in the next sub-section.
- Add a minimum 2- x 4-in. scab (A) to the side of existing roof framing member along the edges of new decking such that the new decking can be fastened to the added 2- x 4-in. scab instead of the existing roof framing member (to prevent the additional roof deck fasteners from damaging the existing framing members). Fasten the new 2- x 4-in. scab to existing framing member with 16d nails (or 3-in-long, #8 wood screws) at 4 in. o.c. See Figure 3.



- Fasten the new decking to the supporting roof framing members and the newly added 2-x 4-in. scab (A) in accordance with Table 1 (boards) or Table 2 (sheathing) as appropriate. (Tables 1 and 2 can be found on pages 17 and 18, respectively.)

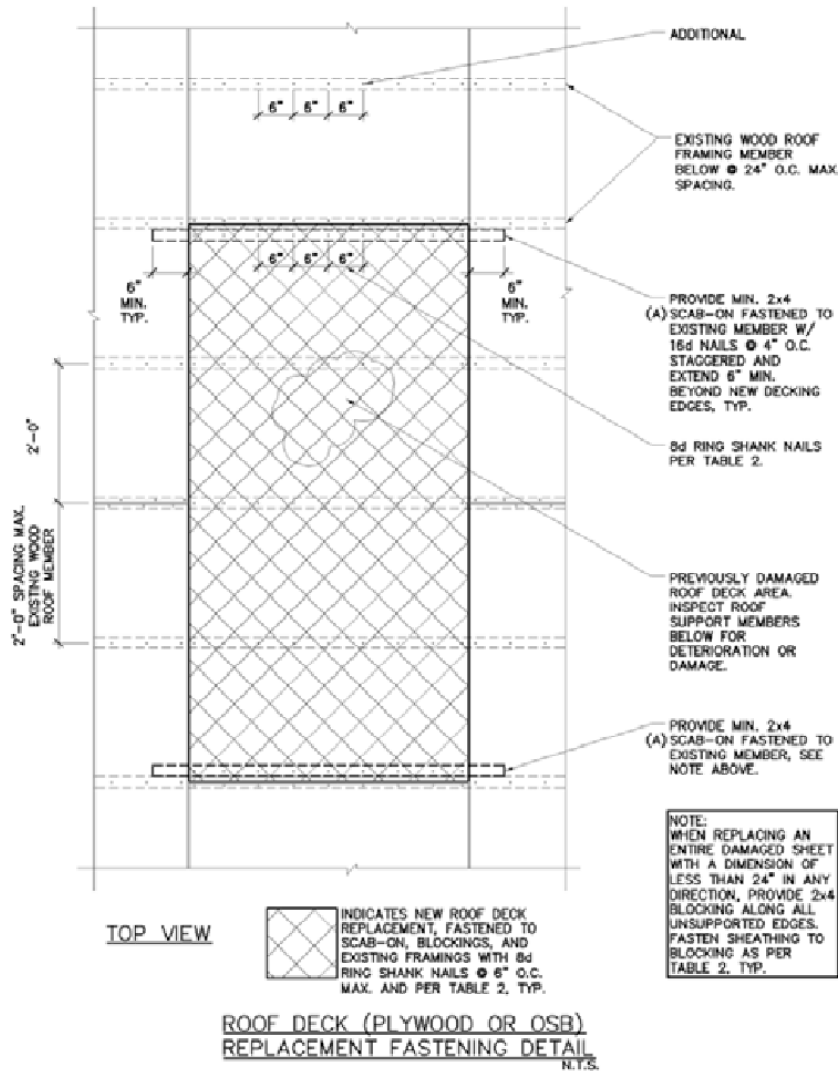

Figure 3. Roof Deck Replacement Details

Note:

When the fascia or sub-fascia is the roof framing member that is damaged or deteriorated, remove and replace the damaged/deteriorated section plus at least 2 ft beyond that section on each side.

Deteriorated or damaged wood roof framing member(s)

On an existing home, deteriorated or damaged wood roof framing member(s) must be repaired prior to installing new roof decking material.

If the roof deck is damaged, there is a possibility the wood roof framing members below the damaged decking are deteriorated or damaged as well. The guidelines listed below provide guidance for repairing wood roof framing members with the relatively minor damage/deterioration described. If the damage is greater than the conditions listed, consult a licensed professional engineer to provide engineering details to repair the damage.

Requirements

The damaged or deteriorated portion of a roof framing member must meet ALL of the following conditions in order to be repaired instead of replaced:

- The roof framing member must be a nominal 2-in-thick (1½ in. actual) and be spaced no more than 24 in. o.c.
- Damaged/deteriorated area must be less than 25% of roof framing member depth.
- Damaged/deteriorated area must not exceed 25% of member length up to an absolute maximum length of 2 ft.
- Damaged/deteriorated area must be a minimum of 6 in. away from any mechanical connections (truss/rafter hangers, truss connector plates, etc.).
- If all conditions listed above are met, a “scab” can be used to repair the damaged roof framing member. The scab should match the size of the damaged roof framing member. For example, a 2- x 4-in. roof truss top chord with damage meeting the conditions listed would require a 2- x 4-in. scab; a 2- x 10-in. rafter with damage meeting the conditions would require a 2- x 10-in. scab. Each scab member must be a continuous piece, extend beyond the damaged portion, as shown in Figure 4, and be fastened to the existing roof framing member with 2 rows of 16d nails (or 3-in-long, #8 wood screws) at 4 in. o.c. The scab may be trimmed up to ½ in. to facilitate installation.
- The roof decking should be fastened to the new scab as indicated in Table 1 for boards or Table 2 for sheathing as appropriate.

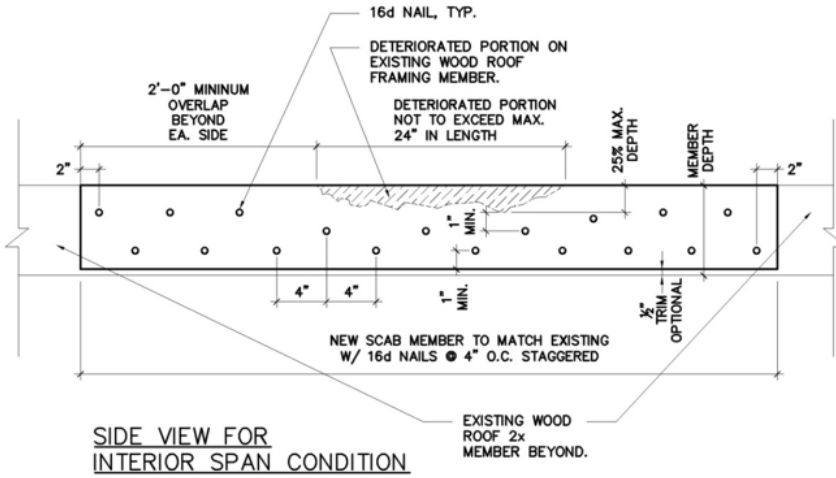

NOTE:
SCAB WOOD MEMBERS MAY BE TRIMMED UP TO A MAXIMUM OF 1/2" AT THE BOTTOM TO FACILITATE INSTALLATION.

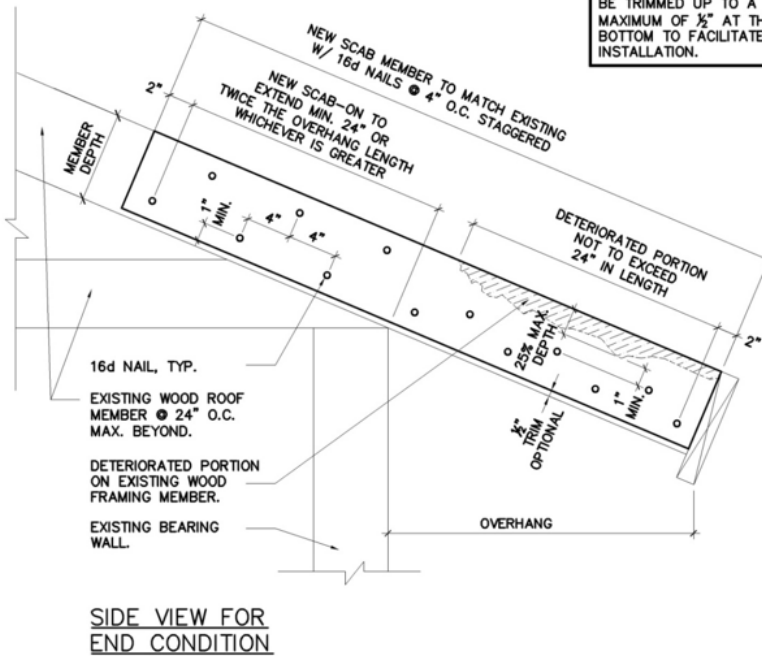

NEW SCAB MEMBER DETAIL FOR DETERIORATED OR DAMAGED WOOD FRAMING MEMBER
N.T.S.

Figure 4. New Scab Member Fastening Details

Strengthening of roof sheathing attachment

Re-nailing the roof decking

Sawn Lumber or Wood Board Roof Decking: Existing Roof

- Add fasteners as required to ensure roof decking consisting of sawn lumber or wood boards up to 1 in. thick are secured with at least 2 nails, having a minimum diameter of 0.131 in. and a minimum length of 2½ in., (3 nails if the board is wider than 8 in.) to each roof framing member it crosses. Framing members must be spaced no more than 24 in. apart. Clipped-head, D-head or round-head nails are acceptable provided they have the required minimum diameter and length.
- For wood boards greater than 1 in. thick and up to 2 in. thick, add fasteners as required to ensure that the decking is secured with at least 2 nails, having a minimum diameter of 0.131 in. and sufficient length to penetrate a minimum of 1½ in. into the roof framing, (3 nails if the board is wider than 8 in.) to each framing member it crosses. Framing members must be spaced no more than 24 in. apart. Clipped-head, D-head or round-head nails are acceptable provided they have the required minimum diameter and length.

Table 1. Fasteners Required For Wood Board Decking Attachment

Wood board/lumber (roof decking) width	Number and minimum dimensions of nails per board for each framing member it crosses.	Maximum spacing of framing members
Up to 8 in.	Two (2) 0.131 in. minimum diameter with 1½ in. penetration into roof framing members	24 in.
Larger than 8 in.	Three (3) 0.131 in. minimum diameter with 1½ in. penetration into roof framing members	24 in.

Structural Wood Panel (Plywood or Oriented Strand Board-OSB) Roof Sheathing

Roof sheathing material must have a minimum thickness of ¾ in. For FORTIFIED Home™ –High Wind Gold, please see note below.

Note: In order to be eligible for any FORTIFIED Home™–High Wind Gold Designation, roof sheathing must have a minimum thickness of $\frac{7}{16}$ in.

Existing Roof (re-nailing the roof decking)

The number and spacing of additional fasteners needed to adequately strengthen the connection of structural wood panel roof sheathing depends on the size, type and spacing of the existing fasteners. With these considerations in mind, the re-nailing solutions outlined below are based on using ring shank nails with full round heads as supplemental fasteners (Figure 5). The specific required minimum dimensions and characteristics for the additional ring shank nails to be used to strengthen the roof deck attachment are:

- Full round head diameter (no clipped head nails allowed)
- $2\frac{3}{8}$ in. minimum nail length
- 0.113 in. diameter

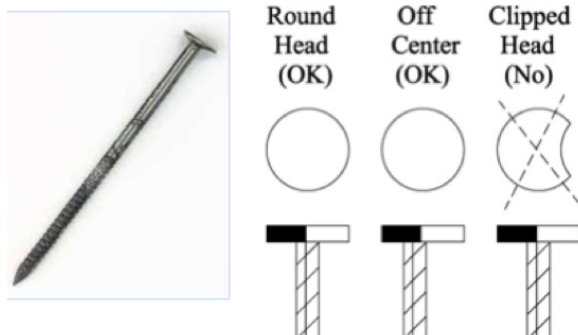

Figure 5. Use 8d ring shank nails as the added fasteners when re-nailing roof sheathing. Research indicates that ring shank nails have about twice the capacity of smooth shank nails.

Nail Head Configurations for Additional 8d Ring Shank Nails

- Only full round head ring shank nails are acceptable.
- Off center ring shank nails with full round heads are acceptable.
- Clipped head ring shank nails are not acceptable.

Table 2. Additional Fasteners at Panel Edges and Intermediate Framing for Roof Deck

Existing Fasteners	Existing Spacing	Required Additional Fastening
Greater than 4 in. o.c. along all panel edges and intermediate framing	Any	Re-nail entire roof deck using one of the following: <ul style="list-style-type: none"> a. 8d common nails or 10d box nails at 4 in. o.c. on all panel edges and intermediate framing b. 8d ring shank nails at 6 in. o.c. on all panel edges and intermediate framing
4 in. o.c. or less along all panel edges and intermediate framing	Greater than 4 in. o.c. along all panel edges and intermediate framing	Install one 8d ring shank nail between each pair of existing fasteners with spacing greater than 4 in., along all panel edges and intermediate framing. Nail spacing between new and existing fasteners not to exceed 4 in. o.c.
6 in. o.c. or less along all panel edges and intermediate framing	4 in. o.c. or less along all panel edges and intermediate framing	None
Greater than 4 in. o.c. along all panel edges and intermediate framing	6 in. o.c. or less along all panel edges and intermediate framing	None

Note:

1. Roof sheathing panels must be a minimum of $\frac{7}{16}$ in. thick for a Gold Designation.
2. Roof framing members must be spaced at maximum of 24 in. o.c. and have a minimum of 2 in. nominal thickness (1½ in. actual thickness).



3. Existing 8d nails to be a minimum of 0.131 in. diameter and 2½ in. long.
4. All additional fasteners are to be 8d ring shank nails (0.113 in. diameter and 2¾ in. long with full round head). See Figure 5.
5. Roof pitch must be 2/12 or greater.

New Roof (attaching the roof deck)

When installing the roof deck on a new home, use one of the following fastening schedules:

1. 8d common nails or 10d box nails at 4 in. o.c. on all panel edges and intermediate framing
2. 8d ring shank nails at 6 in. o.c. on all panel edges and intermediate framing

Note:

1. Roof sheathing panels must be a minimum of $\frac{7}{16}$ in. thick for a Gold Designation.
2. Roof framing members:
 - a. If trusses: To be eligible for Gold Designation, engineered trusses must be designed for minimum 110 mph 3-second gust (ASD) design wind loads for terrain Exposure B.
 - b. If rafter system:
 - i. Collar ties are required on all rafter pairs.
 - ii. To be eligible for Gold Designation, rafters must be sized for span and 110 mph 3-second gust (ASD) design wind loads for terrain Exposure B.
3. If using 8d common nails, nail dimensions to be a minimum of 0.131 in. diameter and 2½ in. long.
4. If using 8d ring shank nails, nail dimensions to be a minimum of 0.113 in. diameter and 2¾ in. long with full round head. See Figure 5.
5. Roof pitch must be 2/12 or greater.

Sealing the roof deck

All new roof cover installations (replacements and new home installations) require a sealed roof deck system that keeps water out of the attic and the interior of the house in the event the roof covering is damaged during high winds. The following are qualified methods for sealing the roof deck.

Options for shingle or metal roofs

Existing Roof (re-roof) or New Roof (installation)

1. Taping of seams between roof sheathing that forms the roof deck. There are two material options for taping the seams on the roof deck:
 - a. Option 1: Apply an ASTM 1970 compliant self-adhering polymer-modified bitumen flashing tape at least 4 in. wide directly to the roof deck to seal the horizontal and vertical joints in the roof deck.
 - b. Option 2: Apply an AAMA 711-13, Level 3 (for exposure up to 80°C/176°F) compliant self-adhering flexible flashing tape at least 3¾ in. wide directly to the roof deck to seal the horizontal and vertical joints in the roof deck.

Any flashing tape used to achieve a sealed roof deck must be fully adhered without voids (e.g., wrinkles) in order to be accepted. See Figure 6. In some instances, the ability of self-adhered flashing tapes to adhere to Oriented Strand Board (OSB) sheathing may be compromised by the level of surface texture, the wax used to release the OSB panel from its mold during the manufacturing process, and/or job site conditions. In applications where flashing tape adhesion to OSB is marginal, apply a primer to the OSB panels where the tape will be applied to ensure the proper attachment of the self-adhering tape to the sheathing. Do not nail or staple the tape to the roof sheathing. Refer to the manufacturer's recommendations for installation and primer requirements (if applicable). Next, apply a code-compliant #30 ASTM D226 Type II or ASTM D4869 Type IV underlayment over the self-adhering tape. This underlayment must be attached using annular ring or deformed shank roofing fasteners with minimum 1-in-diameter caps (button cap nails) at 6 in. o.c. spacing along all laps and at 12 in. o.c. in the field or a more stringent fastener schedule if required by the manufacturer for high-wind and prolonged exposure installations. Horizontal laps must be a minimum of 2 in. and end laps must be a minimum of 6 in.

2. Install two (2) layers of ASTM D 226 Type II (#30) or ASTM D 4869 Type IV (#30) underlayment in a shingle-fashion, lapped 19 in. on horizontal seams (36-in. roll), and 6 in. on vertical seams. The starter course of felt is to be installed as described below and



shown in Figure 7 (below). Cut 17 in. off one side of the roll and install the remaining 19-in-wide strip of underlayment along the eave, safely tacked in place. Carefully install a 36-in-wide roll of ASTM D 226 Type II (#30) or ASTM D 4869 Type IV (#30) underlayment over the 19-in-wide course of ASTM D 226 Type II (#30) or ASTM D 4869 Type IV (#30) underlayment along the eave. Follow the same procedure for each course, overlapping the sheets 19 in. (leaving a 17 in. exposure). Fasten with one row in the field of the sheet at 12 in. o.c. and one row at the overlaps fastened 6 in. o.c. Fasten underlayment at approximately 6 in. o.c. along the laps and at approximately 12 in. o.c. in the field of the sheet between the side laps.

- a. Secure the underlayment using annular ring or deformed shank nails with 1-in-diameter caps (button cap nails).
3. Cover the entire roof deck with a full layer of self-adhering polymer-modified bitumen membrane meeting ASTM D1970 requirements. This approach provides a waterproof membrane over the entire roof and can greatly diminish the potential for leaks. In some instances, the ability of the self-adhered membranes to adhere to Oriented Strand Board (OSB) sheathing may be compromised by the level of surface texture, the wax used to release the OSB panel from its mold during the manufacturing process, and the job site conditions. In applications where membrane adhesion to OSB is marginal, apply a primer to the OSB panels to ensure the proper attachment of the self-adhering membrane to the sheathing. Roofers are finding that shingles are bonding to many of these membranes and this could lead to damage of the sheathing when it comes time to replace the shingles. Consequently, the membrane should be covered with a bond break such as a #15 ASTM D226, Type I underlayment. This underlayment on shingle roofs only needs to be fastened sufficiently enough to keep it on the roof surface and provide safety to the roofers until the shingles are applied.

Note:

Manufacturers emphasize the need for adequate attic ventilation when this type of membrane is applied over the entire roof. Also, some local building departments prohibit the use of this system. Check with the local building department for restrictions.

4. Apply a reinforced synthetic roof underlayment which has an ICC approval as an alternate to ASTM D226 Type II felt paper. The synthetic underlayment must have minimum tear strength of 20 lb per ASTM D1970 or ASTM D4533. This underlayment must be attached using annular ring or deformed shank roofing fasteners with minimum 1-in-diameter caps (button cap nails) at 6 in. o.c. spacing along all laps and at 12 in. o.c. in the field or a more stringent fastener schedule if required by the manufacturer for high-wind installations. Horizontal laps must be a minimum of 2 in. and end laps shall be 6 in. and all laps must be sealed with a compatible tape or mastic.

Note:

- Weave underlayment across valleys.
- Double-lap underlayment across ridges (unless there is a continuous ridge vent).
- Lap underlayment with minimum 6-in. leg “turned up” at wall intersections; lap wall weather barrier over turned-up roof underlayment.



Figure 6. Installing a Sealed Roof Deck System; Taping the Seams of Roof Sheathing

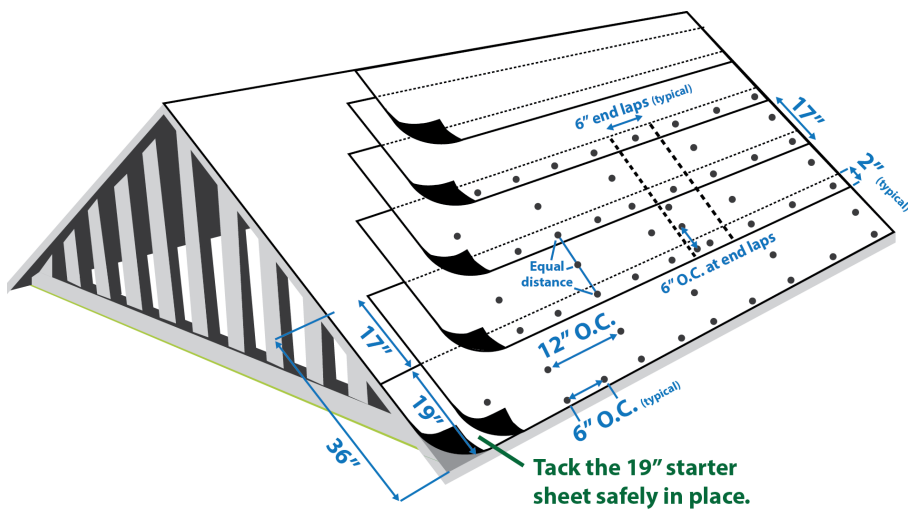

Figure 7. Installation of 19 in. Starter Course General Notes

Options for concrete and clay tile roofs

Concrete and clay tile roofs are inherently porous and can allow water infiltration into the attic when subjected to wind-driven rain. Consequently, it is critical to ensure that the roof surface below is adequately protected by sealing the roof deck. The following options qualify as sealed roof decks under clay and concrete roof tiles. In options 2 and 4, the self-adhering tape provides a required barrier against water intrusion in case the roofing felt begins to lift.

1. The entire roof deck is covered with a full layer of self-adhering polymer-modified bitumen membrane cap sheet meeting ASTM D1970 requirements. In some instances, the ability of the self-adhered membranes to adhere to Oriented Strand Board (OSB) sheathing may be compromised by the level of surface texture, the wax used to release the OSB panel from its mold during the manufacture process, and the job site conditions. In applications where membrane adhesion to OSB is marginal, apply a primer to the OSB panels to ensure the proper attachment of the self-adhering membrane to the sheathing. Note: Some local building departments prohibit the use of this system. Check with the local building department for restrictions.
2. Taping of seams between roof sheathing that forms the roof deck. There are two material options for taping the seams on the roof deck.
 - Option 1: Apply an ASTM 1970 compliant self-adhering polymer-modified bitumen flashing tape at least 4 in. wide directly to the roof deck to seal the horizontal and vertical joints in the roof deck.
 - Option 2: Apply an AAMA 711-13, Level 3 (for exposure up to 80°C/176°F) compliant self-adhering flexible flashing tape at least 3¾ in. wide directly to the roof deck to seal the horizontal and vertical joints in the roof deck.

Any flashing tape used to achieve a sealed roof deck must be fully adhered without voids (e.g., wrinkles) in order to be accepted. See Figure 8. In some instances, the ability of self-adhered flashing tapes to adhere to Oriented Strand Board (OSB) sheathing may be compromised by the level of surface texture, the wax used to release the OSB panel from its mold during the manufacturing process, and/or job site conditions. In applications where flashing tape adhesion to OSB is marginal, apply a primer to the OSB panels where the tape will be applied to ensure the proper attachment of the self-adhering tape to the sheathing. Do not nail or staple the tape to the roof sheathing. Refer to the manufacturer's recommendations for installation and primer requirements (if applicable). Next, apply a code-compliant #30 ASTM D226 Type II or ASTM D4869 Type IV underlayment over the self-adhering tape. This underlayment must be attached using annular ring or deformed shank roofing fasteners with minimum 1-in-diameter caps (button cap nails) at 6 in. o.c. spacing along all laps



and at 12 in. o.c. in the field or a more stringent fastener schedule if required by the manufacturer for high-wind and prolonged exposure installations. Horizontal laps must be a minimum of 2 in. and end laps must be a minimum of 6 in. Finally, apply a self-adhering polymer-modified bitumen cap sheet complying with ASTM D1970 over this underlayment.

3. Apply flashing tape over seams on the roof deck.
 1. Option 1: Apply an ASTM 1970 compliant self-adhering polymer-modified bitumen flashing tape at least 4 in. wide directly to the roof deck to seal the horizontal and vertical joints in the roof deck.
 2. Option 2: Apply an AAMA 711-13, Level 3 (for exposure up to 80°C/176°F) compliant self-adhering flexible flashing tape at least 3¾ in. wide directly to the roof deck to seal the horizontal and vertical joints in the roof deck.

Any flashing tape used to achieve a sealed roof deck must be fully adhered without voids (e.g., wrinkles) in order to be accepted. See Figure 8. In some instances, the ability of self-adhered flashing tapes to adhere to Oriented Strand Board (OSB) sheathing may be compromised by the level of surface texture, the wax used to release the OSB panel from its mold during the manufacturing process, and/or job site conditions. In applications where flashing tape adhesion to OSB is marginal, apply a primer to the OSB panels where the tape will be applied to ensure the proper attachment of the self-adhering tape to the sheathing. Do not nail or staple the tape to the roof sheathing. Refer to the manufacturer's recommendations for installation and primer requirements (if applicable). Next, apply a code-compliant #30 ASTM D226 Type II or ASTM D4869 Type IV underlayment over the self-adhering tape. This underlayment must be attached using annular ring or deformed shank roofing fasteners with minimum 1-in-diameter caps (button cap nails) at 6 in. o.c. spacing along all laps and at 12 in. o.c. in the field or a more stringent fastener schedule if required by the manufacturer for high-wind and prolonged exposure installations. Horizontal laps must be a minimum of 2 in. and end laps must be a minimum of 6 in. Finally, hot mop the underlayment using hot asphalt and apply a #90 mineral surface cap sheet.

4. Install two (2) layers of ASTM D 226 Type II (#30) or ASTM D 4869 Type IV (#30) underlayment in a shingle-fashion, lapped 19 in. on horizontal seams (36-in. roll), and 6 in. on vertical seams.

The starter course of felt is to be installed as described below and shown in Figure 8. Cut 17 in. off one side of the roll and install the remaining 19-in-wide strip of underlayment along the eave, safely tacked in place.



Carefully install a 36-in-wide roll of ASTM D 226 Type II (#30) or ASTM D 4869 Type IV (#30) underlayment over the 19-in-wide course of ASTM D 226 Type II (#30) or ASTM D 4869 Type IV (#30) underlayment along the eave. Follow the same procedure for each course, overlapping the sheets 19 in. (leaving a 17 in. exposure). Fasten with one row in the field of the sheet at 12 in. o.c. and one row at the overlaps fastened 6 in. o.c.

Fasten underlayment at approximately 6 in. o.c. along the laps and at approximately 12 in. o.c. in the field of the sheet between the side laps.

- Secure the underlayment using annular ring or deformed shank nails with 1-in-diameter caps (button cap nails).

Note:

- Weave underlayment across valleys.
- Double-lap underlayment across ridges (unless there is a continuous ridge vent).
- Lap underlayment with minimum 6-in. leg “turned up” at wall intersections; lap wall weather barrier over turned-up roof underlayment.

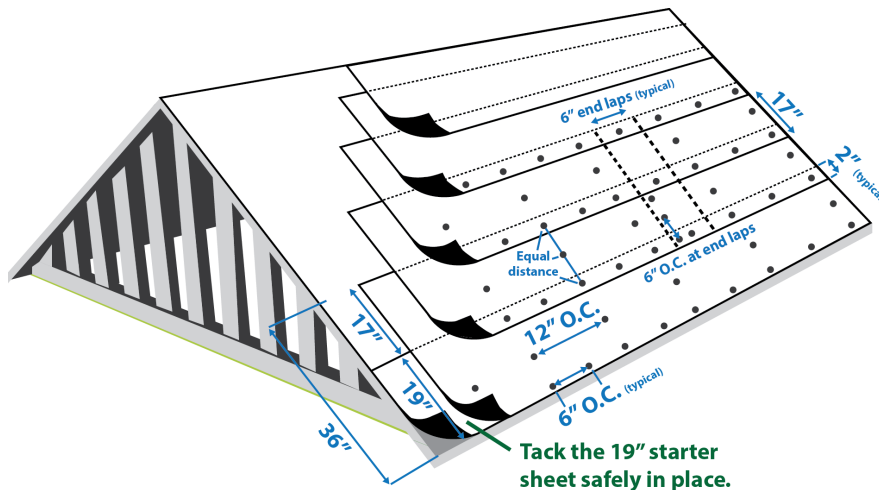

Figure 8. Installation of 19 in. Starter Course General Notes

Drip Edge Requirements

For asphalt shingle roof covers, provide drip edge at eaves and the rakes at gables. Overlap drip edge at joints a minimum of 3 in. Eave drip edges must extend ½ in. below sheathing and extend back on the roof a minimum of 2 in. Drip edge at eaves is permitted to be installed either over or under the underlayment. The drip edge must be mechanically fastened to the roof deck at a maximum of 12 in. o.c. Mechanical fasteners should be applied in an alternating

(staggered) pattern along the length of the drip edge with adjacent fasteners placed near opposite edges of the leg/flange of drip edge on the roof.

Flashing Requirements

Roof membranes must be taped and sealed around all roof penetrations. For flashing at roof penetrations, changes in roof slope and intersections with walls or building features, follow the recommendations given in the NRCA Roofing and Waterproofing Manual or the FRSA/Tile Roofing Institute guide.

Installing qualified roof covering (re-roof or new roof installation)

Asphalt Shingles

Wind Testing/Rating Standards

The American Society of Testing and Materials (ASTM) is a standards organization that publishes technical standards for a wide range of materials and products, including test standards for the wind resistance of asphalt shingles. The ASTM shingle wind testing standards and classification system, not the advertised warranty period and warranty wind speed, will determine which class of high-wind rated shingles meet the technical requirements for a specific wind speed. Make sure the shingles chosen meet these test standards and classification and that the installation is in accordance with the manufacturer’s recommendation for high-wind installations. Asphalt shingles, including hip and ridge materials, must meet the shingle testing standard for the appropriate site design wind speed as shown in Table 3.

Note: IBHS testing has demonstrated that asphalt shingles fabricated using polymer-modified asphalt consistently perform better than those fabricated using oxidized asphalt. Consider selecting shingles fabricated using SBS or SEBS polymer-modified asphalt.

Table 3. Design Wind Speed Classifications for Shingles to be Used in FORTIFIED Home™–High Wind

Design Wind Speed	Shingle Wind Testing Standard/Classification
110 mph ASD	ASTM D3161 (Class F) or ASTM D7158 Class G or H

Shingle Attachment

Shingles must be installed using the number of fasteners required by the manufacturer for high-wind fastening. In areas where the local building code requires more fasteners than required by the manufacturer, fasteners must comply with the local building code.

Clay and Concrete Roof Tiles

Clay and Concrete Tile Wind Resistance Requirement

Clay and concrete roof tile systems and their attachment must meet the requirements for a 110 mph design wind speed for Exposure B. Clay and concrete roof tiles must be installed in accordance with FRSA/Tile Roofing Institute installation guidelines, “Concrete and Clay Roof Tile Installation Manual Fourth Edition, FRSA/TRI 07320/08-05,” for a design wind speed of 110 mph (ASD) and Exposure B. Mortar-set tile or mortar-set hip and ridge tiles (System Three listed in FRSA/TRI Manual) are not permitted. Hip and ridge boards must be attached to the roof framing to resist the uplift pressure in accordance with Table 11 of the FRSA/TRI Manual using a minimum of 110 mph Exposure B requirements. Hip and ridge tiles must be secured to the hip and ridge boards with mechanical fasteners and/or an approved roof tile adhesive.

Note:

FRSA/Tile Roofing Institute installation guidelines, “Concrete and Clay Roof Tile Installation Manual Fourth Edition, FRSA/TRI 07320/08-05,” are available for purchase from the Tile Roofing Institute or the Florida Roofing, Sheet Metal and Air Conditioning Contractor’s Association.

Table 4. Design Wind Speed Resistant Classification

Design Wind Speed
110 mph (ASD)

Metal Panels

Metal Roof Wind Resistance Requirement

Metal panel roofing systems and their attachment must be installed in accordance with the manufacturer’s installation instructions and must provide uplift resistance equal to or greater than the design uplift pressure for the roof based on a 110 mph ASCE 7-05 (140 mph ASCE 7-

10) design wind speed for Exposure B. The metal panels must be installed over continuous decking and one of the acceptable sealed roof deck underlayment options.

Table 5. Design Wind Speed / Metal Roof Classification

Design Wind Speed
110 mph (ASD)



Figure 9. Home with tree damage

Other roof coverings

For all other roof coverings, documentation must indicate that the roof cover is rated for a design wind speed of 110 mph (ASD) for Exposure B to be eligible for FORTIFIED Home™ – High Wind Designation.

Prune trees to reduce risk of trees falling on house

Falling trees and limbs cause hundreds of millions of dollars of damage each year, as well as personal injuries and deaths. Windstorms and ice storms are leading causes of such damage and injuries.

Requirements

To mitigate potential damage from falling tree branches, removal of all tree branches that overhang the roof is required.

Silver Designation Requirements

General Requirements

The FORTIFIED Home™–High Wind Silver Designations build upon and incorporate the improvements made at the Bronze level.

- Completing all FORTIFIED Home™–High Wind Bronze Designation requirements
- Bracing and anchoring gable ends, including assuring gable end walls are sheathed with wood structural panels or equivalent strength sheathing
- Anchoring wood frame chimneys to the roof structure
- Anchoring attached structures (porches and carports)

Strengthening gables over 4 ft tall and improving the anchorage of attached, covered structures and chimneys to better resist wind-generated uplift loads are important steps to protect a home and its contents against the effects of high winds. Gable height is measured (within the attic) from the top of the ceiling joist or top of the bottom chord of truss to the bottom of rafter or bottom of the top chord of truss. If the attic is inaccessible at the gable, height is measured from the bottom of the eave to the peak of the gable.

Inadequately braced and improperly anchored gable end walls are vulnerable to failure during high winds. If the house has a gable end wall that is 4 ft tall or taller, and it is not properly braced and anchored, its failure can cause significant damage to the home.

Gable end walls subjected to high wind must have structural sheathing attached to the vertical face to prevent sheathing loss and resulting high wind and water intrusion into the attic space. The requirement is a minimum of $\frac{3}{8}$ -in. OSB/plywood sheathing attached to the vertical face of all gable ends (regardless of height).

If the home does not have clips, straps or anchors tying the roof structure of attached porches or carports to the supporting structure and the foundation, strong winds can damage these attached structures and they can become windborne debris, which ultimately can cause damage to the main structure.

Chimney framing that extends above the roof deck must be properly anchored to prevent the chimney from collapsing during high winds. Chimney collapse can lead to interior water intrusion and damage, as well as damage to other structures in the area.

Detailed Requirements

Strengthening Gables Over 4 Ft Tall

Gable End Wall Sheathing

Gable end walls must have structural wall sheathing (minimum of $\frac{3}{8}$ -in. plywood or OSB or equivalent).

Gable End Wall Bracing

Gable end walls need to be braced. There are several different approaches that can be used for new construction.

For wood frame roof structures, if framing of the gable is not complete and a professional engineer is NOT being used to design a bracing solution, a contractor/builder can install continuous 2- x 4-in. lateral bracing at the ceiling from the gable end truss to the opposite end of the attic at 6 ft o.c. Each lateral brace must have a minimum 20 gauge metal strap connected to the lateral brace that also wraps over the bottom chord of the gable end wall plate/truss, and for wood frame wall construction below, over the top plate of wall below and is connected to a stud in wall below. When the wall below is masonry, the strap must connect to the bond beam at the top of the wall. The strap must be fastened with ten (10) 8d nails at each end of the strap when the wall below is wood frame or by masonry screws to the bond beam when the wall below is masonry. Blocking (2- x 4-in.) must be added in the bay between the gable wall framing and first ceiling joist or truss and attached to the bottom of each lateral brace with four (4) 10d nails.

If framing of the gable is not complete and a professional engineer is NOT being used to design a bracing solution, a contractor/builder can find alternative guidance for gable end bracing details in the Wood Frame Construction Manual GUIDE TO WOOD CONSTRUCTION IN HIGH WIND AREAS FOR ONE- AND TWO-FAMILY DWELLINGS (WFCM) (http://www.awc.org/pdf/WFCM_110-B-Guide.pdf). The contractor will need to complete the Gable End Bracing Compliance Form – Installation (GEB 2) which can be obtained from a Certified FORTIFIED Home™ Evaluator.

An alternative to using the WFCM guide is to use the Gable End Bracing Retrofit Guide developed by IBHS. This guide can be found in Appendix A. This alternative is appropriate if a gable wall is already framed, structural sheathing is already installed and a professional engineer is not providing a bracing design. The contractor will need to complete the Gable End Bracing Compliance Form – Installation (GEB 2) which can be obtained from a Certified FORTIFIED Home™ Evaluator.

A third alternative is to work with a professional structural engineer to design a custom bracing solution for each gable wall in the home. The custom design must provide the structural capacity necessary to resist wind loads for a design wind speed of 110 mph in Exposure B. The installing contractor will need to follow the details of that design. Both the engineer and the contractor will need to complete the Gable End Bracing Compliance Forms (GEB 1 and GEB 2) which can be obtained from a Certified FORTIFIED Home™ Evaluator.

Prescriptive Methods for Existing Homes

Prescriptive methods for retrofitting gables 4 ft tall and taller are detailed in Appendix A and are consistent with methods included in an appendix to the International Existing Building Code (IEBC). These methods are intended for applications where the gable end wall framing is provided by a wood gable end truss or a conventionally framed rafter system. These prescriptive methods of retrofitting are intended to increase the resistance of existing gable end construction to out-of-plane wind loads.

Five issues are addressed:

1. Strengthening the vertical framing members of the gable end with the use of retrofit studs (See Appendix A)
2. Bracing the top and bottom of the gable end so the lateral loads are transmitted into the roof and ceiling diaphragms through horizontal braces (See Appendix A)
3. Making connections between horizontal braces and retrofit studs using metal straps and fasteners (See Appendix A)
4. Connecting the bottom of the gable end to the wall below using metal bracket connectors (See Appendix A)
5. Making sure that the gable end wall sheathing is adequate (minimum requirement is for $\frac{3}{8}$ -in. OSB/plywood sheathing)

Minimum requirements for use of prescriptive methods detailed in Appendix A are:

- The ceiling diaphragm must be a minimum of $\frac{1}{2}$ -in. drywall, $\frac{3}{8}$ -in-thick plywood, or plaster installed over wood lath.
- The roof sheathing must be at least $\frac{3}{8}$ -in. plywood or OSB or $\frac{3}{4}$ -in. boards.
- Gable ends must have structural wall sheathing (minimum of $\frac{3}{8}$ -in. plywood or OSB or equivalent). If not, sheathing must be added that meets these minimum requirements as part of the retrofit.

Cases that are not covered in this retrofit guidance require that a licensed professional engineer design a gable end bracing system that will meet wind forces appropriate for the location. Note: Gable ends that are not covered in this retrofit guidance include:

- Gable end walls on rooms with vaulted or cathedral ceilings
- Gable ends that are taller than 16 ft and/or have irregular shape

Securing Chimneys

Chimney framing that extends above the roof deck must be properly anchored to prevent the chimney from collapsing during high winds. Chimney structures are vulnerable when the vertical framing members are just nailed to the top of roof deck without adequate anchorage to roof framing members below. Chimney collapse can lead to interior water intrusion and damage, as well as damage to other structures in the area. A prescriptive measure for strengthening wood frame chimney enclosures located within the interior of the roof and extending less than 5 ft above the roof deck is provided. Chimneys that extend greater than 5 ft above the roof deck or that are located along the edge of the roof are beyond the scope of the prescriptive strengthening solution and require engineering review and detailing by a professional engineer.

Prescriptive retrofit measures

For strengthening chimneys extending 5 ft or less above the roof that are located within the interior of the roof:

1. Each corner of the chimney structure must have a tension strap fastened to the corner stud that continues downward to the roof support members below. The tension strap must have a minimum tension capacity of 500 lb.
2. The chimney must be sheathed with structural panels that are at least $\frac{7}{16}$ in. thick on all four sides.
3. The base of the chimney framing must be continuously supported by blocking under the entire perimeter of the chimney. The blocking must be at least nominal 2- x 4-in. wood members and fastened to roof framing members with joist hangers.

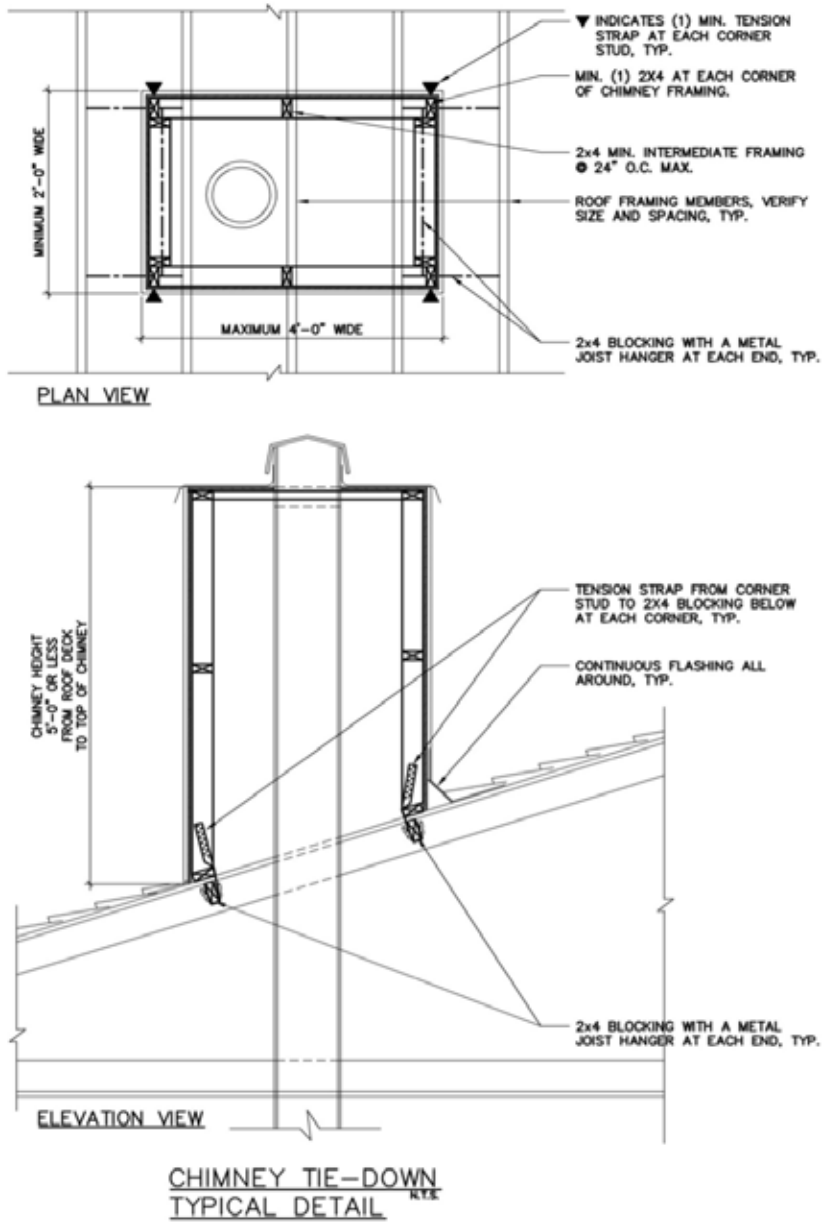

Figure 10. Prescriptive Anchorage Solution for Wood Frame Chimney

When this prescriptive solution is used the contractor will need to complete the Continuous Load Path Compliance Form – Installation (CLP 2) which can be obtained from a Certified FORTIFIED Home™ Evaluator.

Engineering-Based Measures

For chimneys that intersect the roof at the edge or extend 5 ft or more above the roof deck, an engineered solution will be required. A professional structural engineer will need to analyze and design (if necessary) a custom solution for each chimney.

The engineering analysis should address the following issues and provide detailed drawings (if additional connections are necessary) showing any required modifications:

- Chimney wall framing adequacy
- Overall over-turning stability and base shear capacity
- Adequacy of roof support members and bracing
- Adequacy of the chimney structure attachment and anchorage to the existing structure

If the analysis shows that additional anchorage is required, the installing contractor will need to follow the details of the designs provided by the engineer. Both the engineer and the contractor will need to complete the Continuous Load Path Compliance Forms (CLP 1 and CLP 2) which can be obtained from a Certified FORTIFIED Home™ Evaluator.

Anchoring Attached Structures (Porches and Carports)

Existing Home

These covered, attached structures are usually supported by horizontal beam members sitting on vertical columns, which are then connected to foundation systems. These connections are often concealed by finished materials. It may be necessary to remove trim and or ceiling material in order to determine if the required connections are present. No work should be performed until an analysis of these connections is completed. If it is determined that qualified connections are not present, modifications will be necessary. Follow the guidance provided under New Home below.

New Home

Adequate anchoring of these structures requires 3 steps:

1. Provide metal connectors between the supporting roof members and the horizontal beams. The uplift load on this connection can be determined by completing the Porch/Carport Uplift Worksheet.



- a. Wood-to-wood connections: The saddle-type hurricane clip (e.g., H10 or HS10 type clips) may be installed on either side of the beam when the determined uplift force is less than 800 lb. (See Figure 11.) If the uplift force is greater than 800 lb, then a saddle-type hurricane clip must be installed on both sides of the beam.
2. Provide a metal connector at the top of each beam-to-column connection. The uplift load required for this connection can be determined by completing the Uplift Worksheet. Select one of the connections shown in Figure 12. The determined uplift force must be smaller than the stated allowable uplift capacity corresponding to the selected connection.
 - a. Metal connectors and fasteners used in outdoor installations and exposed to moisture should meet, at minimum, the following corrosion protection standards:
 - i. For metal connectors (uplift anchors, column bases, column caps): Hot-dip galvanized in accordance with ASTM A653, G185 designation.
 - ii. For fasteners (nails, screws): Hot-dip galvanized in accordance with ASTM A153, Class D.
 - b. For coastal/waterfront and exterior environments where a higher level of corrosion resistance is desired, use type 316 stainless steel connectors and fasteners.
 - c. For exterior applications with no regular exposure to moisture, use metal connectors with a G90 coating and ASTM A641, Class 1 fasteners.
 - d. Install hardware in accordance with the manufacturer's recommendation.
 - e. Provide a moisture barrier between the bottom of metal connectors and concrete.
3. Provide a metal connector at each column-to-foundation connection. The uplift load required for this connection can be determined by completing the "Prescriptive Porch/Carport Uplift Worksheet." Select one of the connections shown in Figure 13 with an allowable uplift capacity that exceeds the uplift force determined using the Porch/Carport Uplift Worksheet.
 - a. Metal connectors and fasteners used in outdoor installations and exposed to moisture should meet, at minimum, the following corrosion protection standards:
 - i. For metal connectors (uplift anchors, column bases, column caps): Hot-dip galvanized in accordance with ASTM A653, G185 designation.



- ii. For fasteners (nails, screws): Hot-dip galvanized in accordance with ASTM A153, Class D.
- b. For coastal/waterfront and exterior environments where a higher level of corrosion resistance is desired, use type 316 stainless steel connectors and fasteners.
- c. For exterior applications with no regular exposure to moisture, use metal connectors with a G90 coating and ASTM A641, Class 1 fasteners.
- d. Install hardware in accordance with the manufacturer’s recommendation.
- e. Provide a moisture barrier between the bottom of metal connectors and concrete.

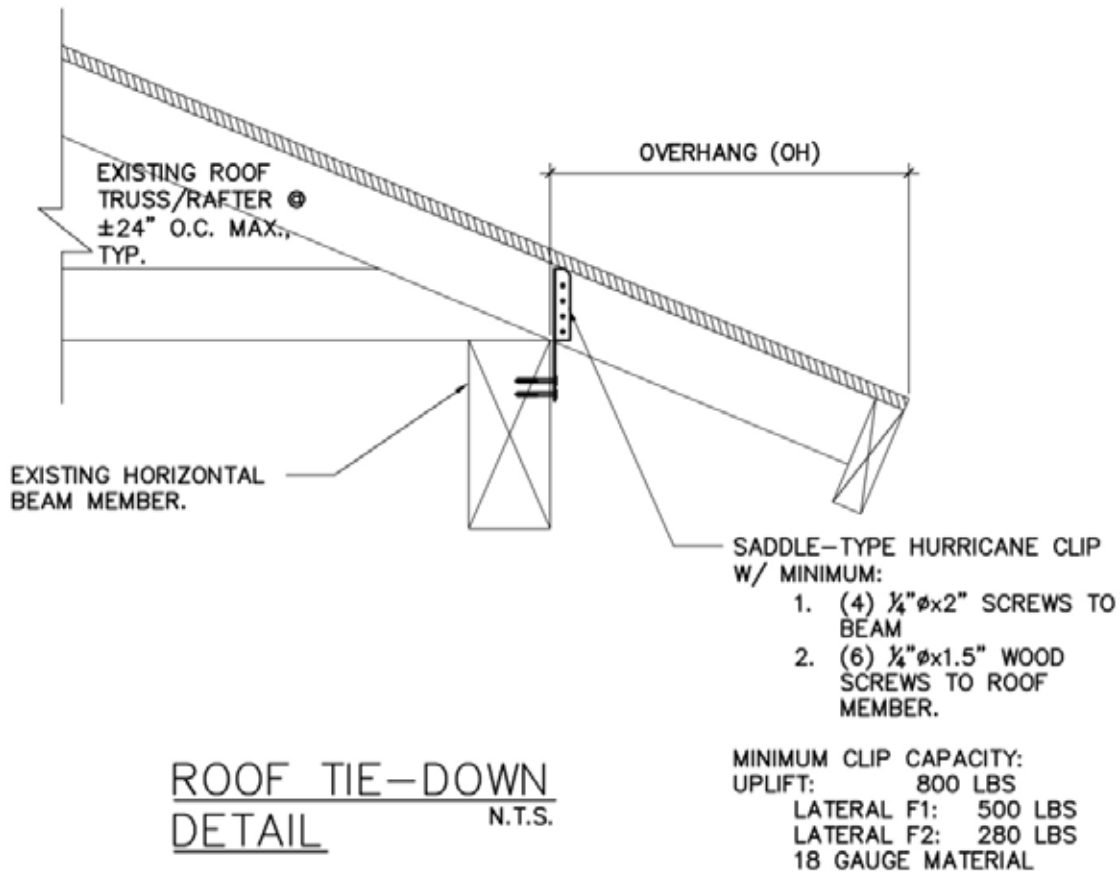

Figure 11. Roof Tie-Down Details

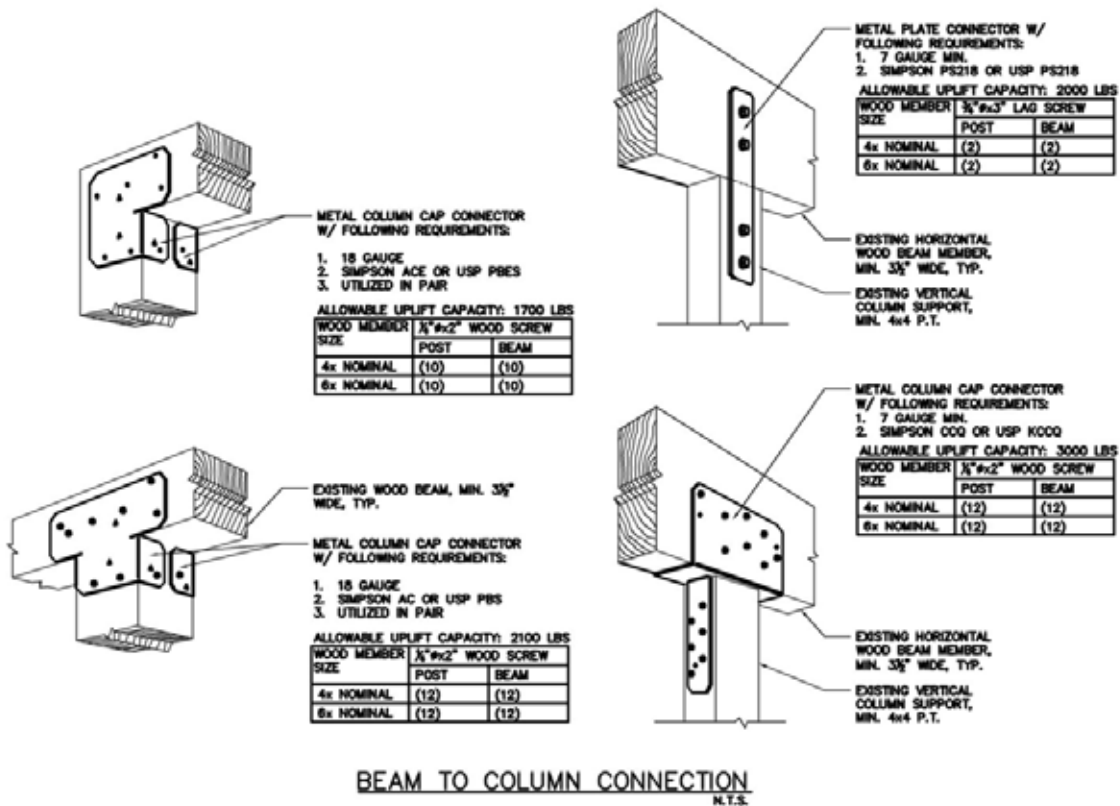

Figure 12. Beam-to-Column Connection

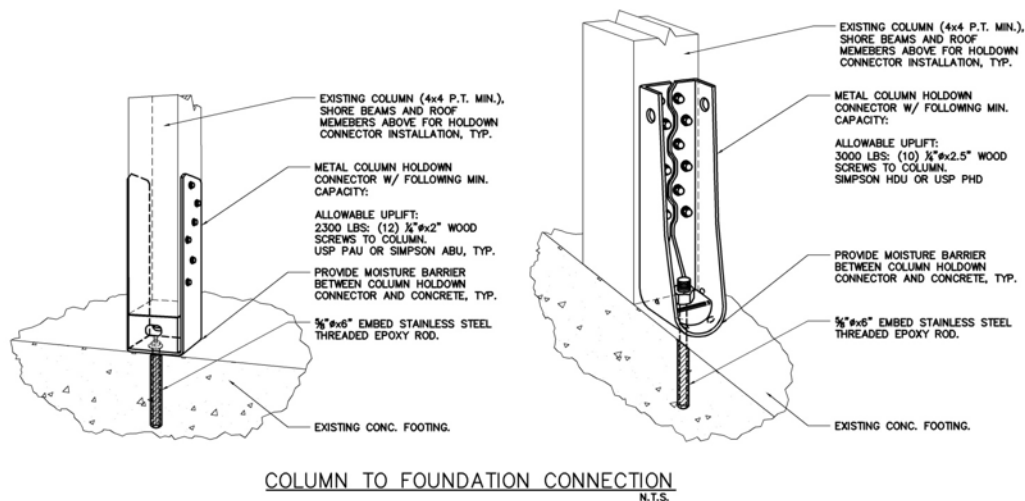

Figure 13. Column-to-Foundation Connection; Typical Column-to-Footing Retrofit Connection

Prescriptive Porch/Carport Uplift Worksheet

Use the following guidelines to determine how much uplift resistance is required to provide adequate carport/porch column connections at both the top and bottom. A continuous load path must be achieved from the roof framing members to the supporting beam, from the beam to the column, and then from the column to the foundation.

1. Measure how far the porch roof sticks out from the wall, $D = \underline{\hspace{1cm}}$ ft.
2. Measure the width of the porch parallel to the house wall, $W = \underline{\hspace{1cm}}$ ft.
3. Measure the roof member spacing, $S = \underline{\hspace{1cm}}$ ft.
4. Measure the roof overhang distance, $OH = \underline{\hspace{1cm}}$ ft.
5. Count the number of columns supporting the roof (whole number = N). (Count each end wall as a single column that supports the roof, maximum 1 at each end.)
6. Column support area can be calculated as following: Inside Column Area (A)= $D/2 \times W/(N-1)$ Corner Column Area (A)= $D/2 \times W/(2(N-1))$
7. Select the appropriate net uplift pressure (wind pressure minus weight) for the design wind speed at your house from the Uplift Pressure Table below (Table 6), $P = \underline{\hspace{1cm}}$ psf.
8. The roof member uplift force can be calculated as follows: $P_{up} = P * (D/2 + OH) * S = \underline{\hspace{1cm}}$ lb.
9. The uplift force on the beam-to-column and column-to-foundation can be calculated by multiplying the net uplift pressure times the typical area, $P*A = \underline{\hspace{1cm}}$ lb.
10. This is the uplift on each column, on the connection at the top of the column, and also on the connection at the bottom of the column. If the column is heavy (e.g., concrete or masonry) then you can reduce the force on the connection at the bottom of the column by the weight of the column.

Table 6. Typical Roof Uplift Pressure, Exposure C, and Mean Roof Height of 15 ft. For Exposure B, Multiply Wind Uplift Pressure by 0.85 and Subtract Weight of Roof to Determine Net Uplift Pressure on Roof

Wind Speed (mph)	Wind Uplift Pressure (lb per sq ft) (psf)	Weight of Roof (psf)	Net Uplift Pressure on Roof (psf)
110 (ASCE 7-05) 140 (ASCE 7-10)	39	10	29

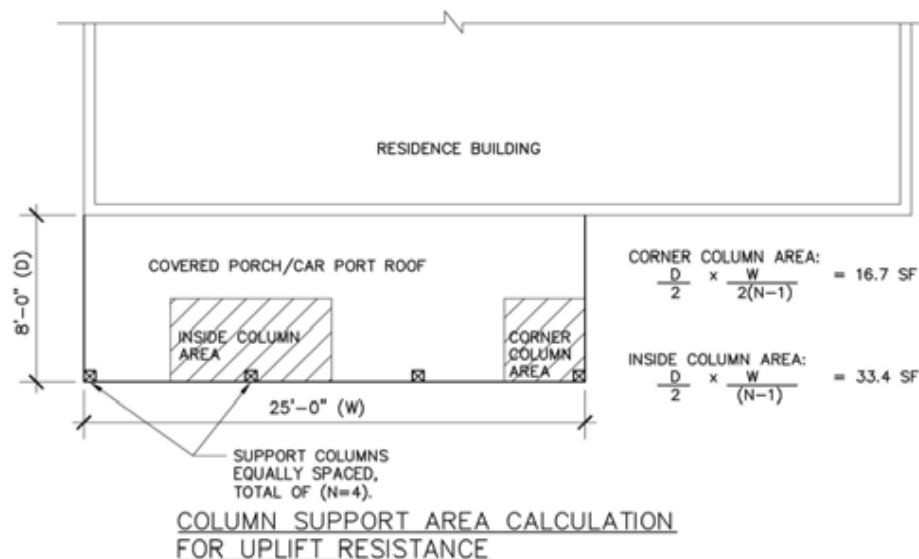

Figure 14. Column Support Area Calculation for Uplift Resistance

Example Calculation and Observations

A porch is 8 ft deep and 25 ft wide with 4 columns along the outside edge of the porch with roof framing members at 2 ft o.c. that extend 1.5 ft beyond the beam (overhang). Consequently: D = 8 ft; W = 25 ft; N = 4; S = 2 ft; OH = 1.5 ft; inside column area (A) = (8/2) x [25/ (4-1)] = 33.4 sq ft; corner column area (A) = (8/2) x [25/2(4-1)] = 16.7 sq ft; If the design wind speed is 110 mph, the net uplift pressure on the roof (P) is 29 psf.

Then P*A is 969 lb for inside columns and 484 lb for corner columns. The uplift force at the roof member and beam intersection is: $P_{up} = 29 * (8/2 + 1.5) * 2 = 319 \text{ lb}$

The supporting foundation needs to be heavy enough to resist the total uplift forces at the eave of the porch roof (2,906 lb). Assuming a 25-ft-long footing that is 6 in. deep and 12 in. wide under a 4-in-thick concrete slab (0.83 sq ft cross-section including the thickness of the slab), with a concrete weight of 150 lb per cubic ft, the weight would be 3,112 lb which would be enough to resist the uplift.

For projects where the FORTIFIED “Prescriptive Porch/Carport Uplift Worksheet” is not used or for porches or carports that do NOT have wood-to-wood connections (e.g., wood-to-concrete) an engineered solution will be required. A professional structural engineer will need to analyze and design (if necessary) the appropriate connections.

Connections Designed by an Engineer

The engineering analysis should address the following issues and provide detailed drawings showing any required connections:

- Roof-to-beam connection
- Beam-to-supporting-member connection (e.g., beam-to-column)
- Supporting-member-connection-to-foundation connection

Anchorage that is required and shown in the engineering design must be installed per the design. Both the engineer and the contractor will need to complete the Continuous Load Path Compliance Forms (CLP 1 and CLP 2) which can be obtained from a Certified FORTIFIED Home™ Evaluator.

Gold Designation Requirements

General Requirements

The FORTIFIED Home™–High Wind Gold Designations build upon and incorporate the improvements made at the Bronze and Silver levels.

1. Completing all FORTIFIED Home™–High Wind Bronze and Silver Designation requirements.
2. A Continuous Load Path (CLP) provides connections to resist wind pressures and resulting loads using 110 mph 3-second gust (ASD) design wind loads for terrain Exposure B.
3. Garage doors must be reinforced to meet design pressures associated with 110 mph ASCE 7-05 (140 mph ASCE 7-10) design wind speeds.

For an existing home, a FORTIFIED Home™–High Wind Gold Designation evaluation can be conducted simultaneously with a Bronze or Silver evaluation. However, it is more likely that the Gold evaluation would follow a Bronze or Silver evaluation, if it has been determined that the home will achieve at least a Silver Designation or if the homeowner specifically requests to pursue the Gold Designation.

In any case, the home must be evaluated for compliance with all the Bronze and Silver requirements, and must meet these requirements before being considered for a Gold Designation.

Continuous Load Path (CLP)

Existing Home

In an existing home, it can be very difficult to determine if a home has a continuous load path and if it does, that the load path meets FORTIFIED Home™ requirements. This is due in large part to the fact that many of the connections required to develop a continuous load path are concealed by finished materials (including but not limited to drywall, trim boards, or exterior cladding like siding, stucco or brick). Additionally, it is extremely rare for homes to be designed by an engineer except in high seismic areas or in certain areas subject to hurricane winds because this type of design is not required in order to obtain a building permit.

Therefore, for an existing home, it is necessary to have an analysis performed by a licensed structural engineer, who can then provide a professional opinion about whether an adequate

continuous load path exists. This continuous load path analysis must be based on providing connections to resist pressures using 110 mph 3-second gust (ASD) design wind loads for terrain Exposure B.

If the engineer determines that retrofitting is required to meet FORTIFIED Home™ standards, the engineer will need to provide a retrofit design providing connections to resist wind pressures and resulting loads using 110 mph 3-second gust (ASD) design wind loads for terrain Exposure B.

The engineer's opinion and/or design must provide construction documents prepared by the professional engineer and indicate:

- Design wind speed, exposure category, mean roof height
- Verification of roof, ceiling and floor framing
- Number of stories
- Design of load path from roof to wall and/or specific details indicating method of connection
- Design of load path from upper floors to lower floors and/or specific details indicating method of anchorage of wall above to wall below
- Design of load path from lowest wall to foundation and/or specific details indicating method of connection
- Foundation design that is adequate for wind uplift and lateral loads

The design specifics will be recorded on the Continuous Load Path Compliance Form – Engineering (CLP 1) which is available from a Certified FORTIFIED Home™ Evaluator. In addition, the contractor installing the connections specified by the engineer of record will need to complete the Continuous Load Path Compliance Form – Installation (CLP 2) which is available from a Certified FORTIFIED Home™ Evaluator.

New Home

Prescriptive Measures for one-story or two-story buildings where the distance between shear walls is less than or equal to 2.5 times the building width

In addition to the normal fastening schedules specified in Table R602.3(1) of the 2006 or later edition of the International Residential Code (IRC)—except for roof and wall sheathing nailing patterns which are replaced by the following minimum requirements when they are more

stringent than local code requirements—the following minimum fastening and reinforcing requirements are provided as a prescriptive method for providing a qualified FORTIFIED Home™–High Wind Continuous Load Path (CLP).

1. Roof framing system with roof sheathing and sheathing attachment constructed to meet or exceed the following minimum requirements:
 - a. Minimum $\frac{7}{16}$ -in-thick wood structural panels
 - b. Sheathing attached in accordance with one of the following fastening schedules:
 1. 8d common nails or 10d box nails at 4 in. o.c. on all roof framing members
 2. 8d ring shank nails at 6 in. o.c. on all roof framing members
 - c. Roof structure
 1. If trusses—Engineered trusses designed for minimum 110 mph 3-second gust (ASD) design wind loads for terrain Exposure B
 2. If rafter system:
 1. Collar ties on all rafter pairs
 2. Rafters sized for span and 110 mph 3-second gust (ASD) design wind loads for terrain Exposure B
 3. Install strap, with the minimum capacity listed in Table 9, over top of ridge board connecting tops of rafter pairs
2. Anchor roof structure to exterior wall below using metal straps following the requirements listed below:
 - a. Metal straps connecting roof structure to exterior wall system at all wall-to-roof framing connections (trusses and rafters) sized to meet the load requirements of Table 8.
 - b. If wall sheathing is used to transfer loads from top plate in wood frame walls to studs, metal straps connecting the trusses/rafters to the top plate of the wall must be on the same side as the sheathing or additional metal connectors are required to transfer loads from the wall top plate to the wall studs and they must be located on the same side of the top plate as the metal straps connecting the trusses or rafters to the top plate.



- c. Metal straps from trusses/rafters with the minimum capacity listed in Table 8 can be used to connect directly to wall studs in wood frame walls below if they align vertically within 1½ in.
 - d. Wood frame roof structures on masonry walls must be connected to reinforced bond beam at the top of the wall using embedded metal straps that meet the load requirements of Table 8.
 3. Interior shear walls (wood frame walls sheathed with wood structural panels on either side, reinforced masonry walls, or other shear walls, depending on the type of construction) are required when the building length is more than 2.5 times its width. Shear walls must be located at intermediate locations between the end walls so that the distance between shear walls (end or interior shear walls) is never greater than 2.5 times the building's width.
 4. Exterior wall and interior shear wall (if needed) construction:
 - a. Wood frame exterior walls must be fully sheathed including areas above or below wall openings with minimum 7/16-in. wood structural panels. Interior shear walls must be fully sheathed including areas above or below wall openings with minimum 7/16-in. wood structural panels on both wall faces. Wall sheathing shall be attached to the wall framing using the following:
 1. For one-story building or top story of two-story building, wood structural panels shall be fastened to the wall studs with 8d common nails, 10d box nails or 8d ring shank nails at a minimum of 6 in. o.c. along all edges and 12 in. o.c. to framing members in the field of the panels.
 2. For bottom story of two-story building, wood structural panels shall be fastened to the wall studs with 8d common nails, 10d box nails or 8d ring shank nails at a minimum of 3 in. o.c. along all edges and 12 in. o.c. to framing members in the field of the panels.
 - b. Masonry exterior walls and interior shear walls must have bond beams with two (2) #5 bars continuous or lapped at least 25 in. Bond beams must be tied together at corners and at the intersection of interior shear walls with the exterior walls with a minimum 25-in. lap on either side of the corner. The bond beam on interior shear walls shall be continuous across the width of the building. Vertical wall reinforcing shall be tied into the bond beam with a minimum 7½-in. hook. All vertical reinforcing shall be continuous or be lapped at least 25 in. to provide adequate development length. Vertical reinforcing (minimum #5 bars) in masonry walls shall be at all corners, on both sides of openings more than 6 ft wide and not more than 8 ft apart along wall segments without openings. Alternatively,



reinforcing may be designed using masonry design standards for 110 mph 3-second gust ASD design wind loads for terrain Exposure B.

- c. Other wall systems must be built following minimum design requirements for 110 mph 3-second gust (ASD) design wind loads for terrain Exposure B and the roof structural system must be adequately anchored to the wall system using connectors with the minimum capacities provided in Table 9.
5. For multi-story wood frame buildings, load bearing exterior wall systems above and below each floor system shall be connected so that loads pass from the wall system above the floor to the wall system below the floor using one of the following methods to achieve the uplift capacities outlined in Table 9.
 - a. Install metal straps that connect wall studs from the wall above to wall studs in the wall below or from wall studs above to the rim board and from the rim board to the wall studs below. Straps can be installed on each stud or at some other convenient spacing not to exceed 8 ft. For example, a 24-ft roof span with straps installed at 4-ft spacing, the required capacity of the strap would be 680 lb (170 lb multiplied by 4-ft spacing).
 - b. Use continuous sheathing (minimum 4 ft) that spans across the floor depth to connect the upper wall to the lower wall with the specified number of nails listed in Table 10 in the wall studs above the floor and wall studs below the floor. Nail spacing along the studs shall not be less than 3 in.
 6. Strapping is required at ends of openings in wood frame exterior walls when openings are greater than 3 ft wide:
 - a. Strap double top plate to king stud using strapping with 840 lb capacity at each end of opening.
 - b. Strap double top plate to header at 16 in. o.c. using strapping with 420 lb capacity at each connection.
 - c. Strap end of header to jack stud using strapping with 840 lb capacity at each end of header.
 - d. Connect king/jack stud to foundation using strapping with capacity of 1,700 lb at each end of opening.
 7. Anchor floor system and exterior walls to foundation using $\frac{5}{8}$ -in-diameter anchor bolts with 3-in. x 3-in. x $\frac{1}{4}$ -in-thick plate washers using the appropriate spacing described below:



- a. For slab-on-grade, 24-in. spacing of anchor bolts and within 12 in. of the end of plate. For raised floor foundation including stem-wall foundations:
 1. 72-in. spacing for a one-story structure along exterior walls in long direction of building
 2. 56-in. spacing for a two-story structure along exterior walls in long direction of building
 3. 36-in. spacing for a one-story structure along exterior walls (and interior shear walls if present) in short direction (across width) of building
- b. 24-in. spacing for a two-story structure along exterior walls (and interior shear walls if present) in short direction (across width) of building

Note: Alternative connections can be developed using guidance provided in Section 2.2 of the American Forest and Paper Association, American Wood Council “Guide to Wood Construction in High Wind Areas for One- and Two-Family Dwellings 110 MPH Exposure B Guide.” If using an alternate method, a description of the connection size and spacing including appropriate references to the American Forest and Paper Association, American Wood Council “Guide to Wood Construction in High Wind Areas for One- and Two-Family Dwellings 110 MPH Exposure B Guide” must be provided to the FORTIFIED Home™ Evaluator.

8. Hold-downs connecting exterior walls and interior shear walls to foundation shall be installed as indicated below:
 - a. For one-story wood frame construction, hold-downs with a minimum allowable capacity of 3,490 lb (for an 8 ft wall height; 4,360 lb for a 10 ft wall height) must be installed at the exterior corners of the building and at the ends of any interior shear walls where they connect to the exterior walls.
 - b. For the top story of two-story wood frame construction, straps or hold-downs with a minimum capacity of 3,490 lb for an 8 ft wall height (4,360 lb for a 10 ft wall height) are required at each exterior corner and each intersection of an interior shear wall with the exterior wall that connect the corner stud system of the wall above to the corner stud system of the wall below.
 - c. For the bottom floor of a two-story wood frame building, hold-downs with a minimum allowable capacity of the sum of the required capacity for each story must be installed at the exterior corners of the building and at the ends of any interior shear walls where they connect to the exterior walls. For a second-story

wall height of 8 ft and a first-story wall height of 10 ft, the required hold-down capacity for the bottom floor would be 3,490 lb plus 4,360 lb = 7,850 lb.

9. Blocking shall be installed at floor deck edges in the first 2 joist or truss bays from exterior walls for edges where walls are parallel to floor joists or floor trusses. Blocking shall be spaced a maximum of 4 ft o.c. and connected using three (3) 16d nails at each end and two (2) 16d nails through the floor sheathing above. For a second-floor-level floor system, a strap with a minimum capacity of 200 lb shall be installed so that it wraps the outside edge of the double top plate of the wall below and is connected to the bottom of the blocking in the first bay.

10. Gable end bracing is required for systems not using balloon framing or walls with continuous reinforcing to the roof deck level. For wood frame roof structure, install continuous 2- x 4-in. lateral brace at ceiling from gable end truss to opposite end of attic at 6 ft o.c. Each lateral brace to have a minimum 20 gauge metal strap connected to the lateral brace that also wraps over bottom chord of gable end wall plate/truss, over the top plate of wall below and is connected to stud in wall below or to bond beam if wall is masonry construction. Strap to be fastened with ten (10) 8d nails at each end of strap for wood frame wall below or by masonry screws to bond beam for masonry wall below. Blocking (2- x 4-in.) must be added in bay between gable wall framing and first ceiling joist or truss and attached to bottom of lateral brace with four (4) 10d nails.

Table 7. Required Minimum Capacities for Ridge Straps Connecting Pairs of Rafters Based on Roof Span and 24-in. Spacing between Rafters

Roof Span (ft)	12	16	20	24	28	32	36
Strap Capacity (lb)	290	385	485	580	675	775	870

Table 8. Roof-to-Wall Connector Minimum Capacities Based on Roof Span and 24-in. Spacing between Rafters or Trusses

Roof Span (ft)	12	16	20	24	28	32	36
Strap Capacity (lb)	275	335	395	455	510	570	630

Table 9. Floor-to-Floor Connection Loads per Ft of Wall Length Based on Roof Span

Roof Span (ft)	12	16	20	24	28	32	36
Strap Capacity (lb/ft of wall length)	80	110	140	170	195	225	255

Table 10. Number of 8d Common, 10d Box or 8d Ring Shank Nails in Each Stud Required to Transfer Loads from Studs in Wall Above to Studs in Wall below Based on Roof Span Indicated and a Stud Spacing of 16 in.

Roof Span (ft)	12	16	20	24	28	32	36
Number of Nails in Each Top and Bottom Stud for Load Transfer Through Continuous Sheathing	2	3	4	4	5	6	6

Alternate Guidance for Wood Frame Construction

- American Forest and Paper Association, American Wood Council, “Guide to Wood Construction in High Wind Areas for One- and Two-Family Dwellings 110 MPH Exposure B”
- American Forest and Paper Association, American Wood Council, Wood Frame Construction Manual

Garage Door Requirements

Design Pressure Rating Requirements

Garage doors must be tested and approved in accordance with, at a minimum, International Residential Code (IRC) accepted design pressure test standards for a 110 mph 3-second gust (ASD) (140 mph ASCE 7-10) design wind speed (or with locally adopted standards if they are more restrictive). Acceptable IRC design pressure test standards include ANSI/ DASHMA 108 or ASTM E 330 (products must be tested to 1.5 times design pressure). The Florida Building Code

Testing Application Standard, TAS 202 is also acceptable for the FORTIFIED Home™ program. All installations must be in accordance with the manufacturer's instructions. See Appendix B for appropriate garage door wind design pressures.

For homes that are located in neighborhoods surrounded by other buildings and/or trees, the minimum design pressure ratings (based on 30-ft mean roof height) are:

- Minimum Required Single Car Garage Door Pressures are (Positive) 20, (Negative) -22
- Minimum Required Double Car Garage Door Pressures are (Positive) 19, (Negative) -21

For homes that are located in more exposed settings with few buildings and/or there are large open areas (including but not limited to fields, lakes, rivers, and golf courses) adjacent to the home site the minimum design pressure ratings (based on 30-ft mean roof height) are:

- Minimum Required Single Car Garage Door Pressures are (Positive) 27, (Negative) -30
- Minimum Required Double Car Garage Door Pressures are (Positive) 26, (Negative) -28

Existing Homes

It is not possible to determine the design pressure ratings of a garage door simply by looking at the door or the track. If the door has a design pressure label (which is not common) and the design pressures listed meet the criteria above, then the door should meet FORTIFIED Home™ requirements.

Any door that is not labeled or does not have paperwork that indicates that its design pressure ratings meet those outlined above will need to be replaced to meet FORTIFIED Home™ Gold requirements. Any door that is labeled or has documentation but does not meet the design pressure criteria provided above, will need to be retrofitted to meet these pressure requirements or replaced. If the door is retrofitted, documentation will be required certifying that the retrofitted door, hardware, tracks and anchorage match those for a new door from the manufacturer that meets the pressure requirements given above.

Appendix A: Gable End Wall Bracing Retrofit

Introduction

Gable ends are those upper triangular walls that rest on rectangular walls. They don't have horizontal eaves. The triangles may be of various proportions and may be triangles with a section cutoff. Figures A-1 through A-6 show a variety of gable ends. Only gable ends that include an attic are addressed in this guide through retrofitting. It does not address gable end walls where the room behind the wall has a cathedral or vaulted ceiling. Gable ends taller than 4 ft but shorter than 16 ft are the ones that can to be retrofitted with the prescriptive method described in this section.



Figure A-1. House with large and small gable ends.

Figure A-2. Large gable at end with partially exposed gable where house is wider.

Figure A-3. Gable end with attached chimney.

Figure A-4. Cut-off gable over garage with covered entry to side.

Figure A-5. Gable end with intersecting shed roof.

Figure A-6. Gable end over garage and living area.

Wind Forces on Gable Ends: High wind forces both push (inward acting) and pull (outward acting) on houses. It is critical to brace the gable end in both directions.

Typical Traditional Construction Practices: Gable end walls were not necessarily built to withstand the pressures that high winds can impose. Gable ends in some instances may not have structural wall sheathing; in such cases, existing exterior material must be removed and replaced with structural sheathing (minimum of $\frac{3}{8}$ -in. plywood or OSB or equivalent.)

Types of Failures: Basically, there are 3 things to be concerned about with gable end walls:

1. The most common type of failure is loss of roof sheathing from the gable end that results in the gable wall losing its bracing along the top edge. This type of failure is shown in Figure A-7.
2. The second most common type of gable end failure is at the connection between the rectangular and triangular walls as shown in Figure A-8 and Figure A-9.
3. The third potential weak link is the actual framing members that make up the gable end wall structure. In many houses, these members may be a truss or 2x lumber framing.



Figure A-7. The most common gable end failure is one where the wall loses support along its top edge because sheathing is blown off. The wall may fold outward (see cover picture) or be blown inward.



Figure A-8. The second most common type of gable end failure is at the connection between the rectangular and triangular walls. Here, the failure is just starting.



Figure A-9. The more usual result of wall connection failures is a missing gable end wall and the wall below.

Gable Ends Not Covered in this Retrofit Guide: Gable end walls on rooms with vaulted or cathedral ceilings, while common (particularly when facing the coast or water), pose special problems for retrofitting. Unless care was taken in the design and construction of these walls to provide the kind of bracing they need to stand up to strong winds, they are very likely to fail. The structural solutions usually involve beams that either span across the width of the wall or columns that span from floor to ceiling.

Gable ends taller than 16 ft and/or that have irregular shape must be investigated by a licensed engineer who must develop bracing requirements to meet the appropriate design wind forces.

Prescriptive Method

The following pages of Appendix A provide prescriptive guidance for retrofitting wood frame gable end walls with heights between 4 ft and 16 ft.

Section A101 General

A101.1 Intent and purpose. The provisions of this subsection provide prescriptive solutions for the retrofitting of gable ends of buildings. The retrofit measures are not intended to provide strengthening of buildings equal to the structural provisions of the latest building code requirements for new buildings. Design for compliance of new buildings and additions to existing buildings shall conform to the requirements of the appropriate adopted local building code.

A101.2 Scope. The following prescriptive methods are intended for applications where the gable end wall framing is provided by a wood gable end wall truss or a conventionally framed rafter system. The retrofits are appropriate for wall studs oriented with their broad face parallel to or perpendicular to the gable wall surface. An overview perspective drawing of the retrofit is shown in Figure A104.1.

Section A102 Definitions

Anchor Block: A nominal 2-in-thick by at least 4-in-wide piece of lumber secured to horizontal braces and filling the gap between existing framing members for the purpose of restraining horizontal braces from movement perpendicular to the framing members.

Compression Block: A nominal 2-in-thick by at least 4-in-wide piece of lumber used to restrain in the compression mode (force directed towards the interior of the attic) an existing or retrofit stud. It is attached to a horizontal brace and bears directly against the existing or retrofit stud.

Conventionally Framed Gable End: A conventionally framed gable end with studs whose faces are perpendicular to the gable end wall.

Horizontal Brace: A nominal 2-in-thick by at least 4-in-wide piece of lumber used to restrain both compression and tension loads applied by a retrofit stud. It is typically installed horizontally on the top of floor framing members (truss bottom chords or ceiling joists) or on the bottom of pitched roof framing members (truss top chord or rafters).

Retrofit Stud: A nominal 2-in. lumber member used to structurally supplement an existing gable end wall stud.

Right Angle Gusset Bracket: A 14 gauge or thicker metal right angle bracket with a minimum load capacity perpendicular to the plane of either face of 350 lb when connected to wood or concrete with manufacturer-specified connectors.

Stud-To-Plate Connector: A manufactured metal connector designed to connect studs to plates with a minimum uplift capacity of 500 lb.

Truss Gable End: An engineered factory-made truss or site-built truss that incorporates factory-installed or field-installed vertical studs with their faces parallel to the plane of the truss and are spaced no greater than 24 in. o.c. Web or other diagonal members other than top chords may or may not be present. Gable end trusses may be of the same height as nearby trusses or may be drop chord trusses in which the top chord of the truss is lower by the depth of the top chord or outlookers.

Section A103 Materials of Construction

A103.1 Existing Materials. All existing wood materials that will be part of the retrofitting work (trusses, rafters, ceiling joists, top plates, wall studs, etc.) shall be in sound condition and free from defects or damage that substantially reduce the load-carrying capacity of the member. Any wood materials found to be damaged or deteriorated shall be strengthened or replaced with new materials to provide a net dimension of sound wood equivalent to its undamaged original dimensions.

A103.2 New Materials. All materials approved by this code, including their appropriate allowable stresses, shall be permitted to meet the requirements of this chapter.

A103.3 Dimensional Lumber. All dimensional lumber for braces, studs, and blocking shall conform to applicable standards or grading rules. Dimensional lumber shall be identified by a grade mark of a lumber grading or inspection agency that has been approved by an accreditation body that complies with DOC PS 20. All new dimensional lumber to be used for retrofitting purposes shall be a minimum grade and species of #2 Spruce-Pine-Fir or shall have a specific gravity of 0.42 or greater. In lieu of a grade mark, a certificate of inspection issued by a lumber grading or inspection agency meeting the requirements of this code shall be accepted.

A103.4 Metal Plate Connectors, Straps and Anchors. Metal plate connectors, straps and anchors shall have product approval. They shall be approved for connecting wood to wood, or wood to concrete as appropriate. Straps and tie plates shall be manufactured from galvanized steel with a minimum thickness provided by 20 gauge. Tie plates shall have holes sized for 8d nails.

A103.5 Twists in Straps. Straps shall be permitted to be twisted 90 degrees in addition to a 90 degree bend where they transition between framing members or connection points.

A103.6 Fasteners. Fasteners meeting the requirements of Sections A103.6.1 and A103.6.2 shall be used and shall be permitted to be screws or nails meeting the minimum length requirement shown in figures and specified in tables.

A103.6.1 Screws. Screws shall be a minimum #8 size with head diameters no less than 0.3 in. Screw lengths shall be no less than indicated in the Figures and in Tables. Permissible screws include deck screws, wood screws, or sheet metal screws (without drill bit–type tip, but can be sharp pointed). Screws shall have at least 1 in. of thread. Fine-threaded screws or drywall screws shall not be permitted. Note that many straps will not accommodate screws larger than #8.

A103.6.2 Nails. Unless otherwise indicated in the provisions or drawings, where fastener lengths are indicated in Figures and Tables as 1¼ in., 8d common nails with shank diameter 0.131 in. and head diameters no less than 0.3 in. shall be permitted. Unless otherwise indicated in the provisions or drawings, where fasteners lengths are indicated in Figures and Tables as 3 in., 10d common nails with shank diameter of 0.148 in. and head diameters no less than 0.3 in. shall be permitted.

A103.7 Fastener Spacing. Fastener spacing shall be as follows:

1. distance between fasteners and the edge of lumber shall be a minimum of ½ in. unless otherwise indicated,
2. distance between fasteners and the end of lumber shall be a minimum of 2½ in.,
3. distance between fasteners parallel to grain (center-to-center) when straps are not used shall be a minimum of 2½ in. unless a ½-in. stagger (perpendicular to the grain) is applied for adjacent fasteners, then the distance between fasteners parallel to the grain shall be a minimum of 1¼ in.,
4. distance between fasteners across grain (row spacing) when straps are not used shall be a minimum of 1 in., and the
5. distance between fasteners inserted in metal plate connectors, straps and anchors as defined in Section A103.4 (above) shall be those provided by holes manufactured into the straps.

Section A104 Retrofitting Gable End Walls

A104.1 Scope and Intent. Gable ends to be strengthened shall be permitted to be retrofitted using methods prescribed by provisions of this section. These prescriptive methods of retrofitting are intended to increase the resistance of existing gable end wall construction for out-of-plane wind loads resulting from high-wind events. The retrofit method addresses 4 issues.

These include strengthening the framing members of the walls if necessary (retrofit studs), bracing the top and bottom of the gable wall so that lateral loads are transmitted into the roof and ceiling diaphragms (horizontal braces, straps to retrofit studs and compression blocks) and connecting the bottom of the gable end wall to the wall below to help brace the top of that wall (specialty metal brackets).

The following prescriptive methods are intended for applications where the gable end wall framing is provided by a wood gable end wall truss or a conventionally framed rafter system. The retrofits are appropriate for wall studs oriented with their broad face parallel to or perpendicular to the gable wall surface. An overview perspective drawing of the retrofit is shown in Figure A104.1.

A104.2 Horizontal Braces. Horizontal braces shall be installed approximately perpendicular to the top and bottom chords of the existing roof trusses or approximately perpendicular to the rafters and ceiling joists at the location of each existing gable end wall stud greater than 3 ft in length. If the spacing of existing gable end studs is greater than 24 in. or no vertical gable end stud is present, a stud and horizontal braces shall be installed such that the maximum spacing between existing and added studs shall be 24 in. Additional gable end wall studs shall not be required at locations where their length would be 3 ft or less. Each required added stud shall be attached to the existing roofing framing members (truss top chord or rafter and truss bottom chord or ceiling joist) using a minimum of two (2) 3-in. toenail fasteners (#8 wood screws or 10d nails) and a metal connector or mending plate with a minimum of four (4) 1¼-in-long fasteners (#8 wood screws or 8d nails) at each end. The horizontal braces shall consist of the minimum size member indicated in Table A104.2. The horizontal brace shall be oriented with the long face across the top and bottom chords of the wood trusses (or rafters and ceiling joists) and extending a minimum of 3 framing spacings from the gable end wall, plus 2½ in. beyond the last top chord or bottom chord member (rafter or ceiling joist) as shown in Figure A104.2.1 and A104.2.6. The horizontal brace shall be located no farther than ½ in. from the inside face of the gable end wall truss. Each horizontal brace shall be fastened to each existing framing member (top chord or rafter or bottom chord or ceiling joist) that it crosses using three (3) 3-in-long fasteners (#8 wood screws or 10d nails) as indicated in Figures A104.2.2 through A104.2.5 for trusses, and Figures A104.2.7 through A104.2.10 for rafters.

Exceptions:

1. Where obstructions, other permanently attached obstacles or conditions exist that will not permit installation of new horizontal braces at the indicated locations, refer to Section A104.5 for permitted modification of these prescriptive retrofit methods.
2. Where obstructions, other permanently attached obstacles or conditions exist that will not permit extension of the new horizontal braces across the existing framing members a minimum of 3 framing spaces from the gable end wall, the horizontal braces may be shortened provided that all of the following conditions are met:

1. The horizontal brace shall be installed across a minimum of 2 framing spaces and fastened to each existing framing member with three (3) 3-in-long fasteners (#8 wood screws or 10d nails).
2. The minimum size of the anchor block shall be equivalent to the existing framing members. The anchor block shall be fastened to the side of the horizontal brace in the second framing space from the gable end wall as shown in Figure A104.2.11. Six (6) 3-in-long fasteners (#8 wood screws or 10d nails) shall be used to fasten the anchor block to the side of the horizontal brace.
3. The anchor block shall extend beyond the surface of the horizontal brace that is in contact with the existing framing members a minimum of one half the depth of the existing framing member. The anchor block shall be installed tightly between the existing framing members such that the gap at either end shall not exceed $\frac{1}{8}$ in.

A104.3 Retrofit Studs. The retrofit studs shall consist of the minimum size members for the height ranges of the existing vertical gable end wall studs indicated in Table A104.2. Retrofit studs shall be installed adjacent to the existing or added (Section A104.2) vertical gable end wall studs and extend from the top of the lower horizontal brace to the bottom of the upper horizontal brace. A maximum gap of $\frac{1}{8}$ in. shall be permitted between the retrofit stud and the bottom horizontal brace. A maximum gap of $\frac{1}{2}$ in. shall be permitted between the top edge of the retrofit stud closest to the upper horizontal brace and the horizontal brace surface.

Exception:

Where obstructions, other permanently attached obstacles or conditions exist that will not permit the installation of a new retrofit stud adjacent to an existing gable end wall stud, refer to Section A104.5 for permitted modification of these prescriptive retrofit methods.

A104.3.1 Retrofit Stud Fastening. Each retrofit stud shall be fastened to the top and bottom horizontal brace members with a minimum of a 20 gauge, 1¼-in-wide flat metal strap with pre-punched fastener holes. The flat metal straps shall be the minimum length as indicated in Table A104.2. Each top and bottom strap shall extend sufficient distance onto the vertical face of the retrofit stud and be fastened with the number of 1¼-in-long fasteners (#8 wood screws or 8d nails) indicated in Table A104.2. Each strap shall be fastened to the top and bottom horizontal brace members with the minimum number of 1¼-in-long fasteners (#8 wood screws or 8d nails) as indicated in Table A104.2. The retrofit stud members shall also be fastened to the side of the existing vertical gable end wall studs with 3-in-long fasteners (#8 wood screws or 10d nails) spaced at 6 in. o.c. as shown in Figure A104.2.1.

A104.3.2 Retrofit Stud Splices. Retrofit studs greater than 8 ft in height may be field spliced as shown in Figure A104.3.

A104.4 Compression Blocks. Compression blocks shall have minimum lengths as indicated in Table A104.2. Compression blocks shall be installed on the horizontal braces directly against either the existing vertical gable end wall stud or the retrofit stud. For clarity, Figures A104.2.2 through A104.2.5 for trusses, and Figures A104.2.7 through A104.2.10 for rafters, show the installation of the compression block against the existing vertical gable end wall stud with the strap from the retrofit stud running beside the compression block. When the compression block is installed against the retrofit stud, the block shall be allowed to be placed on top of the strap. A maximum gap between the compression block and the existing vertical gable end wall stud member or retrofit stud of $\frac{1}{8}$ in. shall be permitted. Compression blocks shall be fastened to the horizontal braces with the minimum number of 3 in-long fasteners (#8 wood screws or 10d nails). End and edge distances for fastener installation shall be as listed in Section A103.7 and shown in Figures A104.2.2 through A104.2.5 for trusses, and Figures A104.2.7 through A104.2.10 for rafters.

A104.5 Obstructions. Permissible Modifications to Prescriptive Gable End Retrofits. Where obstructions, other permanently attached obstacles or conditions exist in attics that preclude the installation of a retrofit stud or horizontal braces in accordance with Sections A104.2 or A104.3, the gable end retrofit shall be deemed to meet the requirements of this section if the requirements of Section A104.5.1 are met. Obstructions to the installation of retrofit studs or horizontal braces include gable end vents, attic accesses, recessed lights, skylight shafts, chimneys, air conditioning ducts, or equipment. Where the installation of a horizontal brace for the top of a center stud is obstructed by truss plates near the roof peak, methods prescribed in A104.5.1 are permitted to be used, or retrofit ridge ties as prescribed in Section A104.5.2 are permitted to be used to support the horizontal brace.

A104.5.1 Remedial Measures. Where Obstacles Prevent Installation of Retrofit Studs or Horizontal Braces. If a retrofit stud or horizontal brace cannot be installed because of an obstruction, the entire assembly can be omitted from that location provided all of the following conditions are met:

1. No more than 2 assemblies of retrofit studs and horizontal braces are omitted on a single gable end.
2. There shall be at least 2 retrofit studs and horizontal brace assemblies on either side of the locations where the retrofit studs and horizontal bracing members are omitted (no 2 ladder braces bearing on a single retrofit stud).
3. The retrofit studs on each side of the omitted retrofit stud are increased to the next indicated member size in Table A104.2 and fastened as indicated in Section A104.3.1.
4. The horizontal bracing members on each side of the omitted brace shall be sized in accordance with Table A104.2 for the required retrofit studs at these locations.



5. The horizontal bracing members on each side of the omitted brace shall extend a minimum of 3 framing spaces from the gable end wall unless anchor blocks are installed in accordance with Exception 2 of Section A104.2.
6. Ladder bracing is provided across the location of the omitted retrofit studs as indicated in Figures A104.5.1.1 for trusses and A104.5.1.2 for rafters.
7. Ladder bracing shall consist of a minimum 2- x 4-in. members oriented horizontally and spaced at 12 in. o.c. vertically. Ladder bracing shall be attached to each adjacent retrofit stud with a metal framing angle with a minimum lateral capacity of 175 lb. Ladder bracing shall be attached to the existing stud at the location of the omitted retrofit stud with a metal hurricane tie with a minimum capacity of 175 lb.
8. Where ladder bracing spans across a gable end vent, no attachment to the gable end vent framing shall be required.
9. Notching of the ladder bracing shall not be permitted.

A104.5.2 Retrofit Ridge Ties. When obstructions along the ridge of the roof obstruct the installation of a horizontal brace for one or more studs near the middle of the gable wall, retrofit ridge ties may be used to provide support for the required horizontal brace. Retrofit ridge tie members shall be installed a maximum of 12 in. below the existing ridge line. The retrofit ridge tie members shall be installed across a minimum of 3 bays to permit fastening of the horizontal brace. A minimum of a 2- x 4-in. member shall be used for each ridge tie and fastening shall consist of two (2) 3-in-long wood screws, four (4) 3-in-long 10d nails, or two (2) 3½-in-long 16d nails driven through and clipped at each top chord or web member intersected by the ridge tie as illustrated in Figure A104.5.2.

A104.5.3 Notching of Retrofit Studs. Retrofit studs may be notched in one location along the height of the stud member provided that all of the following conditions are met:

1. The retrofit stud to be notched shall be sized such that the remaining depth of the member at the location of the notch (including cut lines) shall not be less than that required by Table A104.2.
2. The notched retrofit stud shall not be spliced within 12 in. of the location of the notch. The splicing member shall not be notched and shall be installed as indicated in Figure A104.3.
3. The length of the flat metal straps indicated in Table A104.2 shall be increased by the increased depth of the notched retrofit stud member to be installed.

4. The height of the notch shall not exceed 12 in. vertically as measured at the depth of the notch.
5. The notched retrofit stud member shall be fastened to the side of the existing gable end wall studs in accordance with Section A104.3.1. Two (2) additional 3-in. fasteners (#8 wood screws or 10d nails) shall be installed on each side of the notch in addition to those required by Section A104.3.1.

A104.6 Connection of Gable End Wall to Wall Below. The bottom chords or bottom members of wood framed gable end walls shall be attached to the wall below using one of the methods prescribed in Sections A104.6.1 or A104.6.2. The particular method chosen shall correspond to the framing system and type of wall construction encountered. Due to access considerations, this retrofit needs to be carried out before any of the other gable end retrofit activities referenced in Sections A104.2, A104.3, A104.4 or A104.5.

A104.6.1 Truss Gable End Wall. The bottom chords of the gable end wall shall be attached to the wall below using right angle gusset brackets consisting of 14 gauge or thicker material with a minimum load capacity of 350 lb perpendicular to the plane of either face of the connector. The right angle gusset brackets shall be installed throughout the portion of the gable end where the gable end wall height is greater than 3 ft at the spacing specified in Table A104.6. A minimum of 2 of the fasteners specified by the manufacturer shall engage the body of the bottom chord. Connection to the wall below shall be by one of the methods listed below:

1. For a wood frame wall below, the 2 fasteners into the top of the wall below that are closest to the face of the gable end bottom chord shall be 4½ in. long and of the same diameter and style specified by the bracket manufacturer. Other fasteners shall be consistent with the bracket manufacturer's specifications for size, style and length.
2. For a concrete or masonry wall below without a sill plate, the fasteners into the wall shall be consistent with the bracket manufacturer's specifications for fasteners installed in concrete or masonry.
3. For a concrete or masonry wall below with a 2x sill plate, the fasteners into the wall below shall be of the diameter and style specified by the bracket manufacturer for concrete or masonry connections, but, long enough to pass through the wood sill plate and provide the required embedment into the concrete or masonry below. Alternatively, the bracket can be anchored to the sill plate using fasteners consistent with the bracket manufacturer's specifications for wood connections provided; the sill plate is anchored to the wall on each side of the bracket by a ¼-in-diameter masonry screw with a 2½-in. embedment into the concrete or masonry wall. ¼-in. washers shall be placed under the heads of the masonry screws.

A104.6.2 Conventionally Framed Gable End Wall. Each stud in a conventionally framed gable end wall, throughout the length of the gable end wall where the wall height is greater than 3 ft, shall be attached to the bottom or sill plate using a stud-to-plate connector. The bottom or sill plate shall then be connected to the wall below using one of the methods listed below:

1. For a wood frame wall below, the sill or bottom plate shall be connected to the top plates below using $\frac{1}{4}$ -in-diameter screws, 4½ in. long. The fasteners shall be installed at the spacing indicated in Table A104.6.
2. For a concrete or masonry wall below, the sill or bottom plate shall be connected to the concrete or masonry wall below using $\frac{1}{4}$ -in-diameter concrete or masonry screws of sufficient length to provide a 2½-in. embedment into the top of the concrete or masonry wall. The fasteners shall be installed at the spacing indicated in Table A104.6.

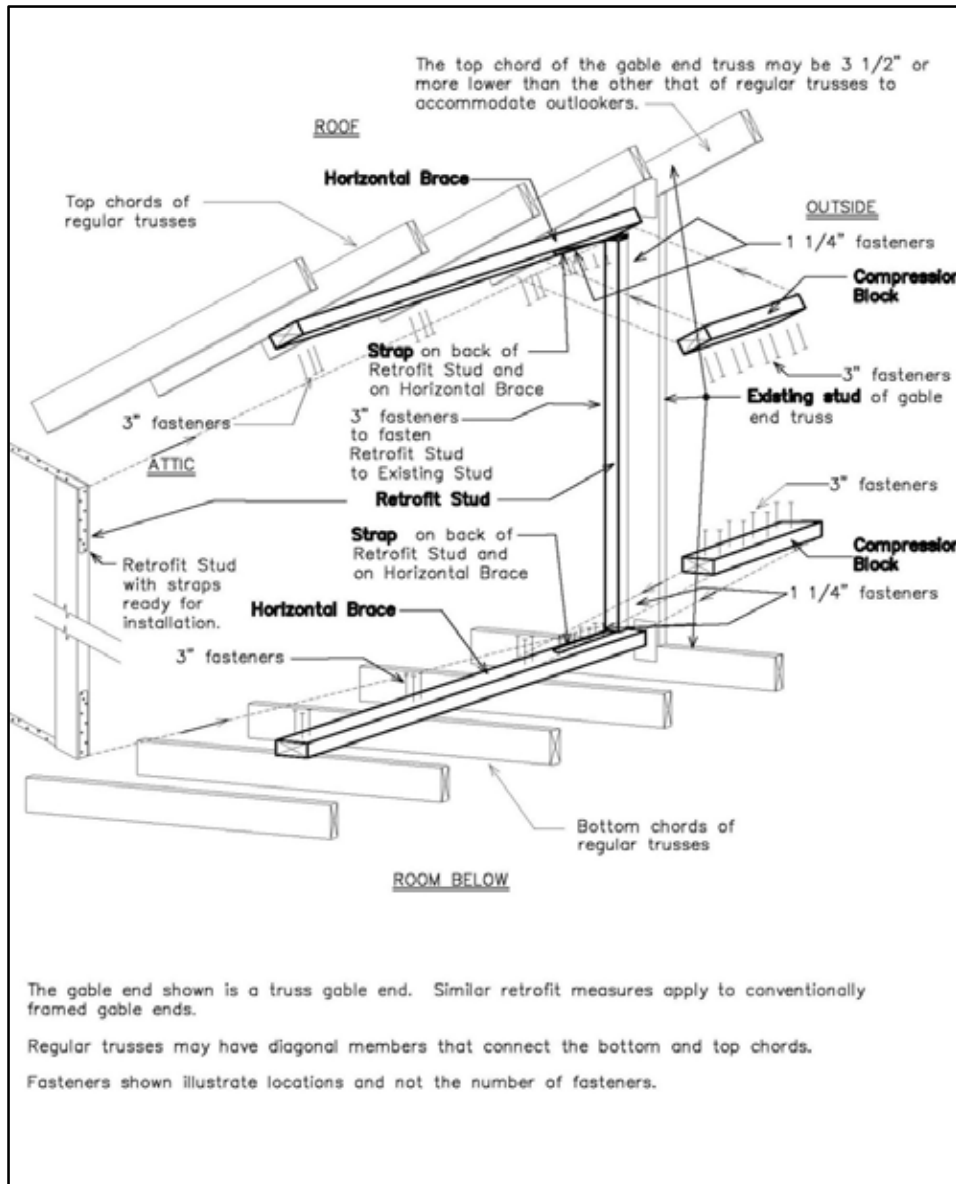

Figure A104.1 Overall sketch showing the concept for strengthening and bracing a gable end wall

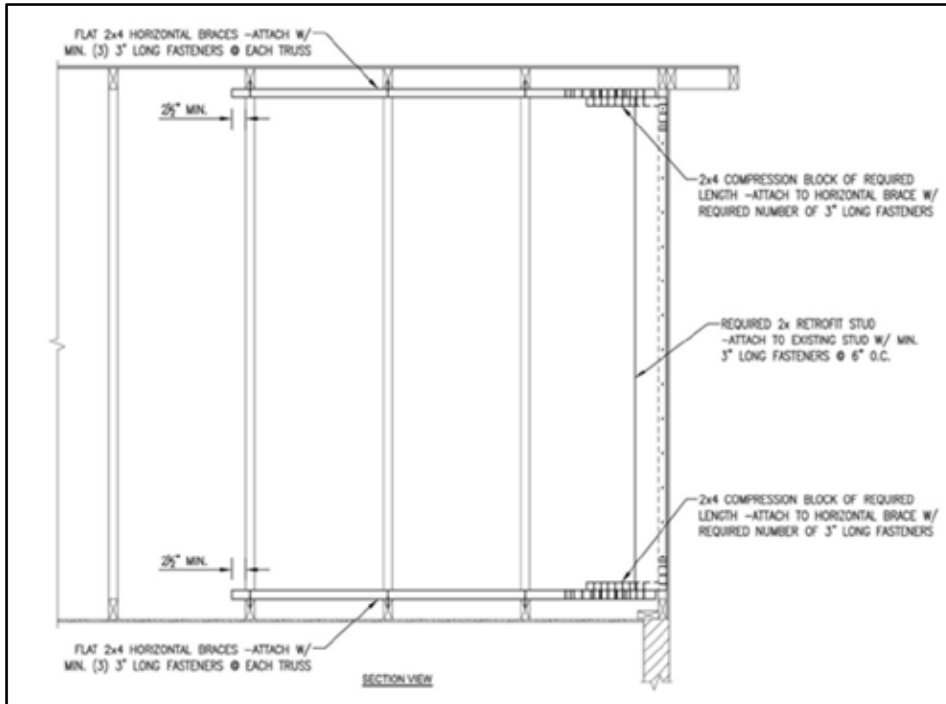

Figure A104.2.1. Gable End Retrofit Components and Connections

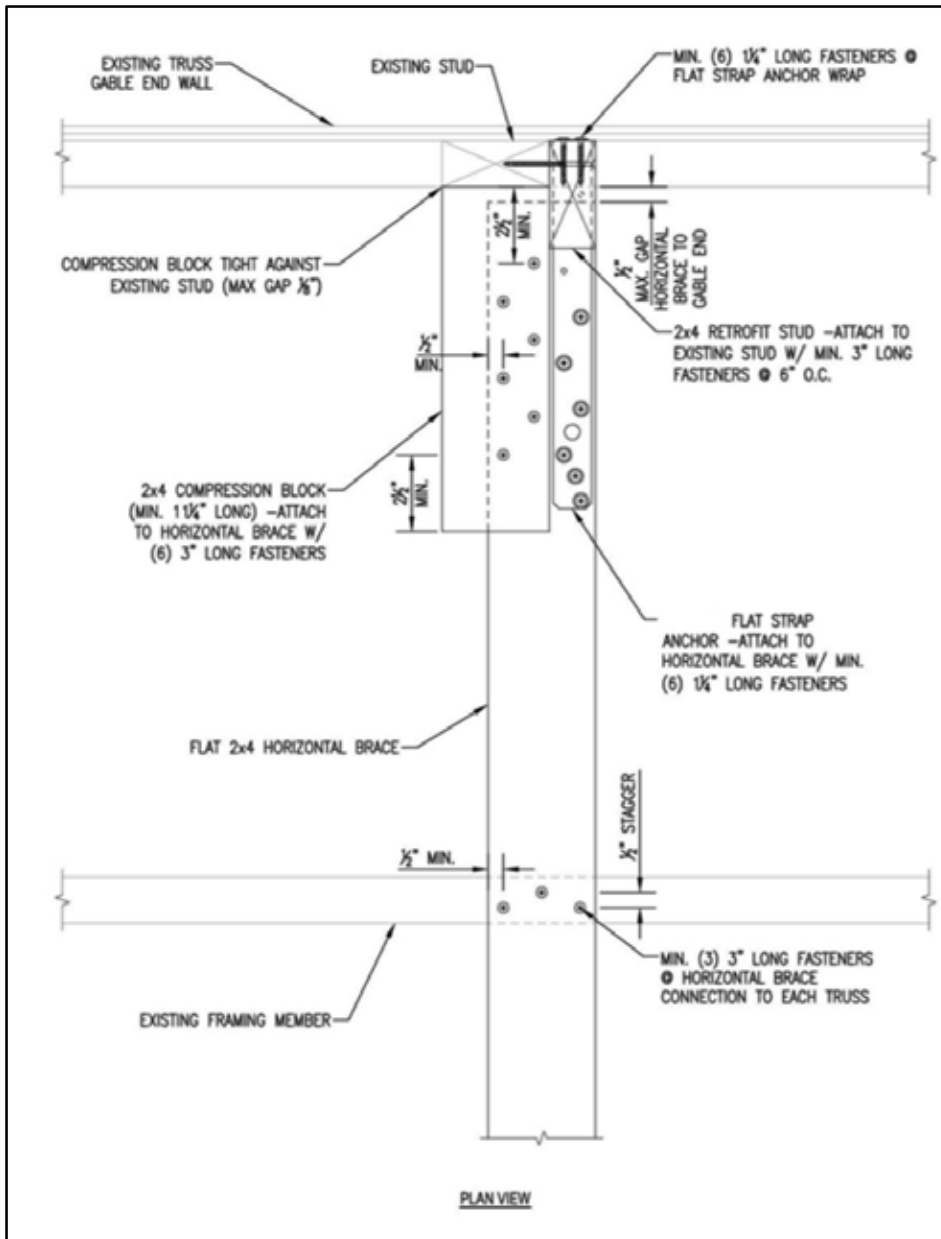

Figure A104.2.2. Details of Strap & Compression Block Installation – 2x4 Retrofit Stud

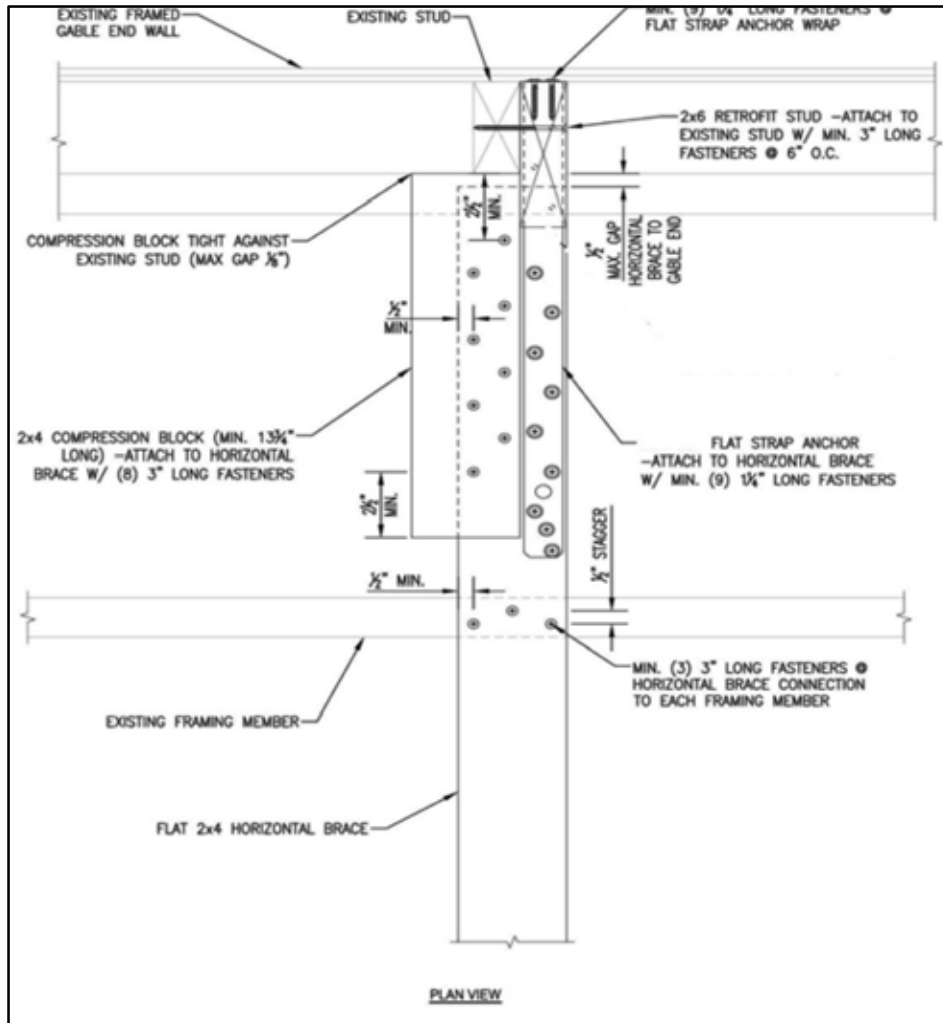

Figure A104.2.3. Details of Strap & Compression Block Installation – 2x6 Retrofit Stud

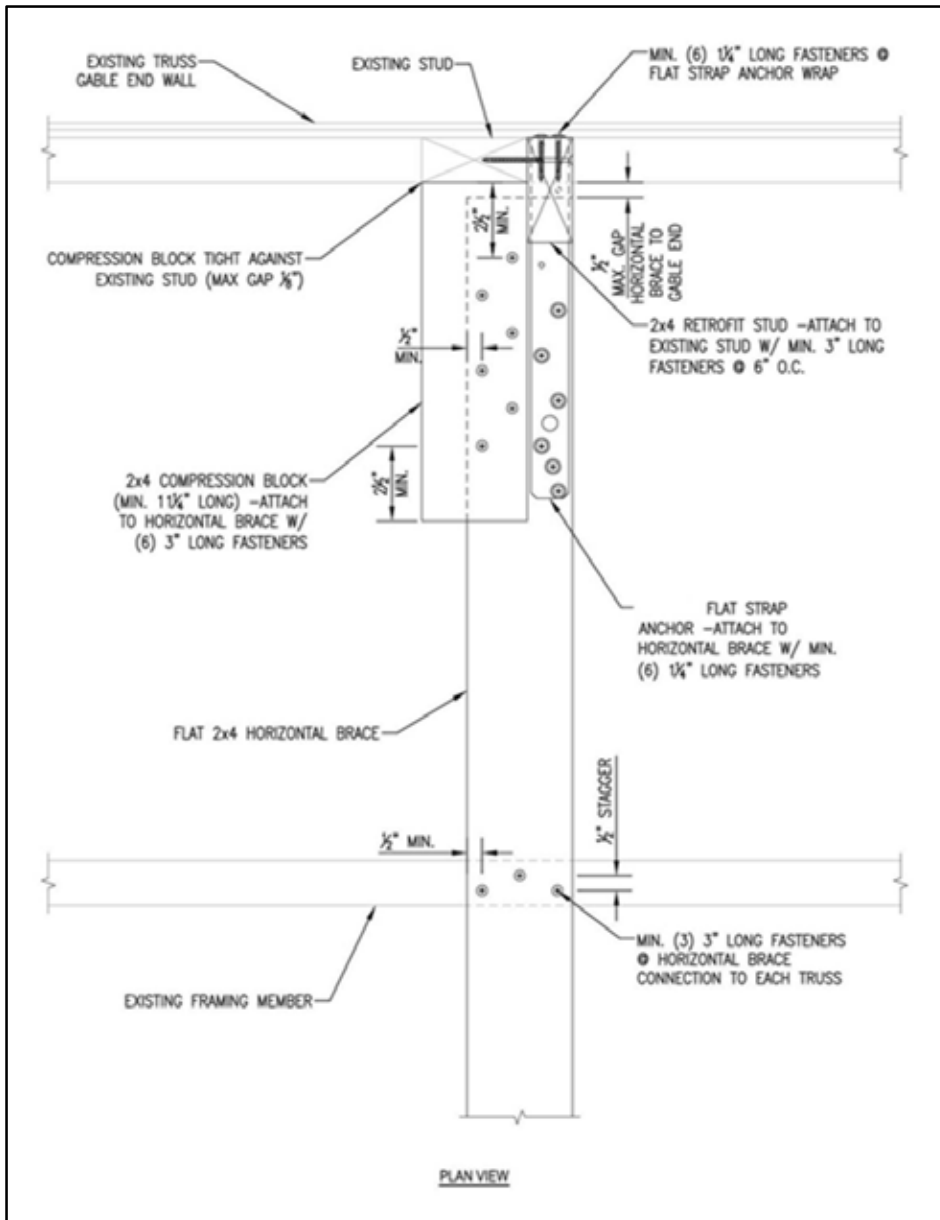

Figure A104.2.4. Details of Strap & Compression Block Installation – 2x8 Retrofit Stud

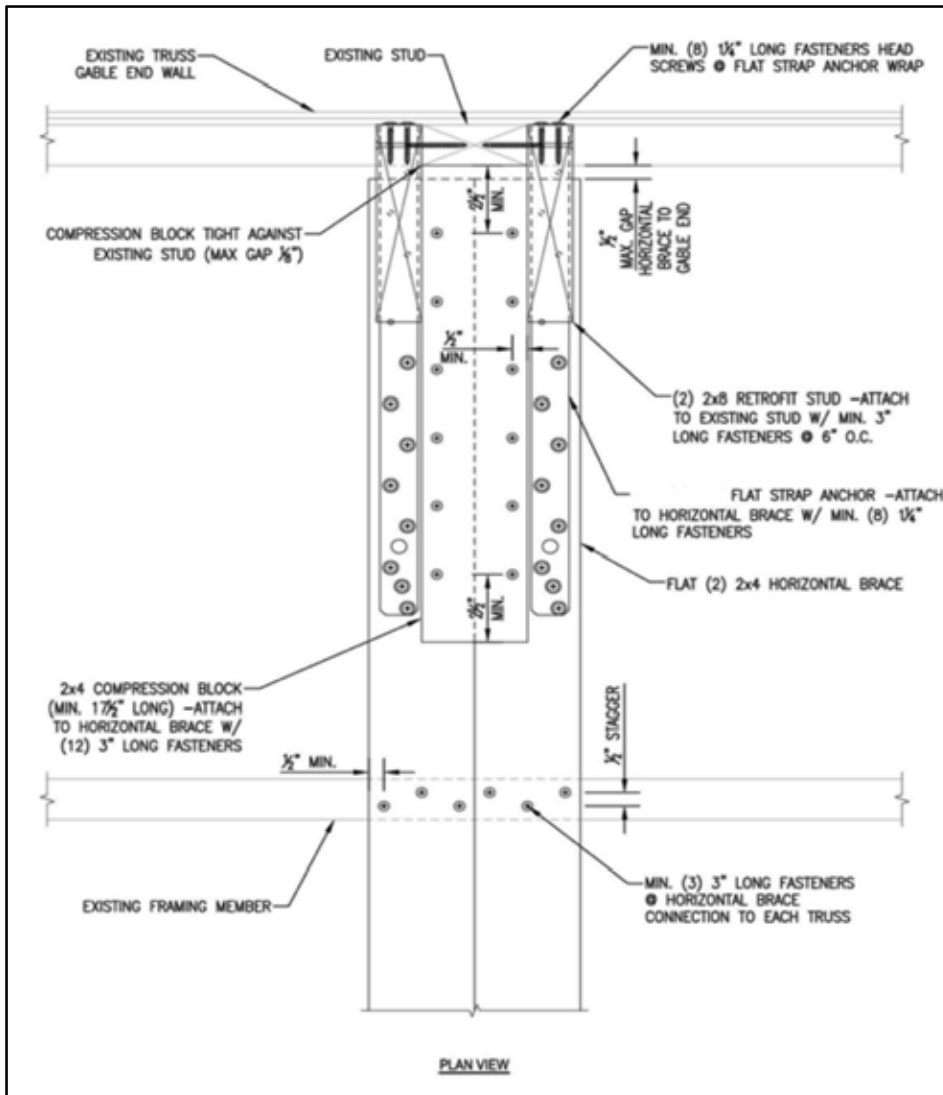

Figure A104.2.5. Details of Strap & Compression Block Installation – (2) 2x8 Retrofit Stud

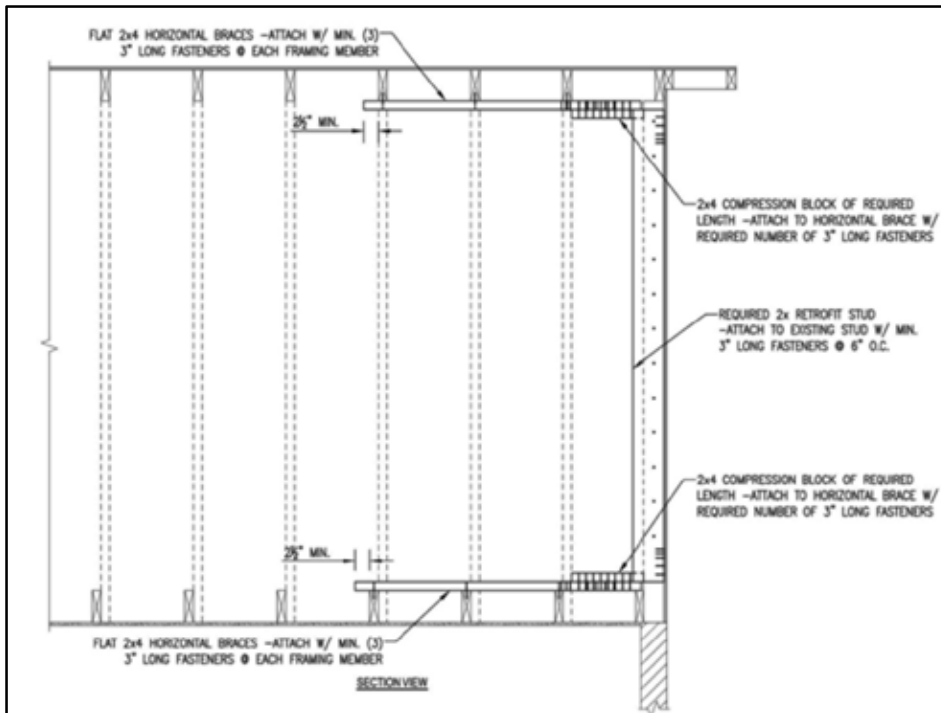

Figure A104.2.6. Section View of Gable End Retrofit (Conventionally Framed)

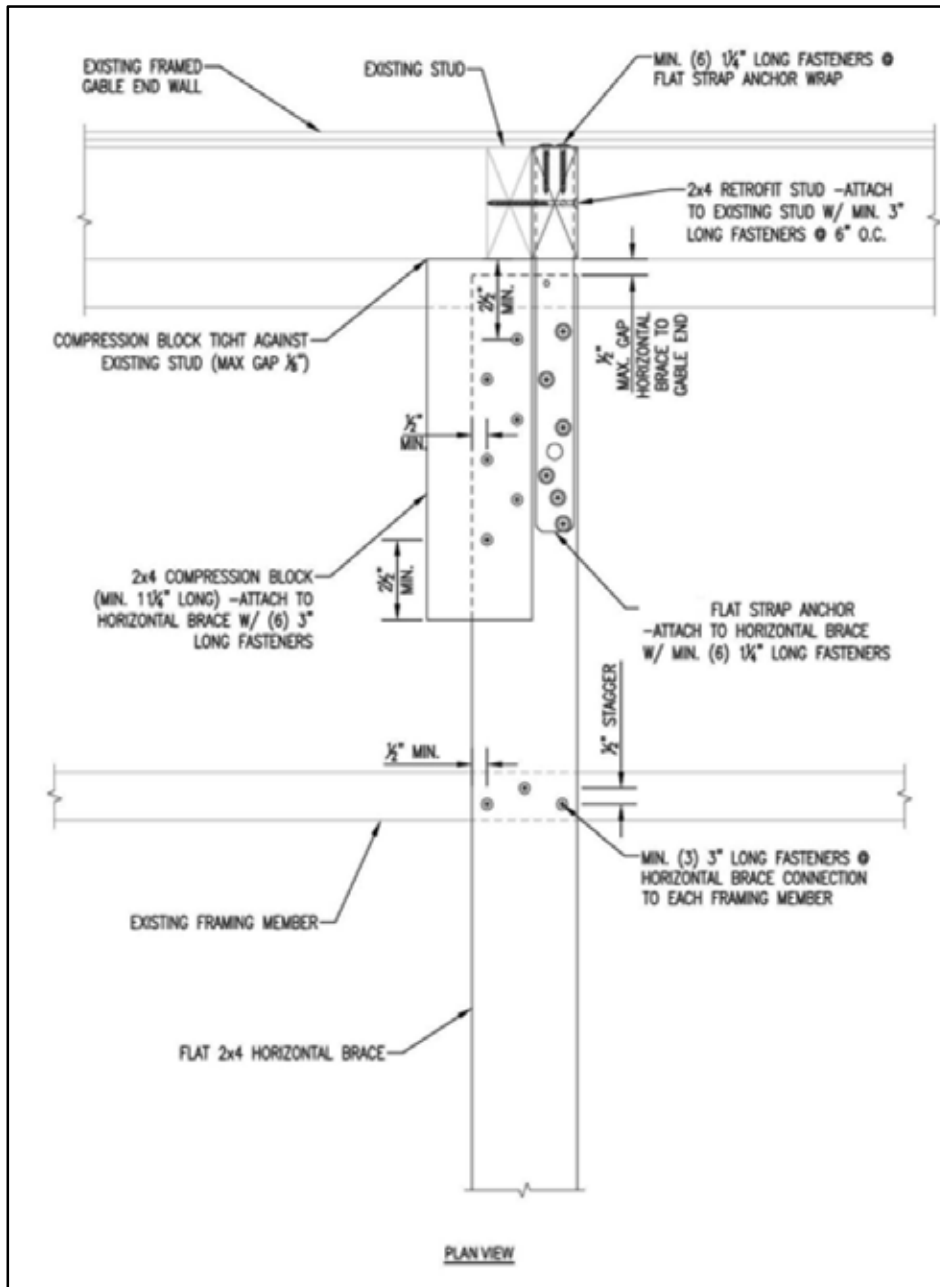

Figure A104.2.7. Details of Strap & Compression Block Installation – 2x4 Retrofit Stud

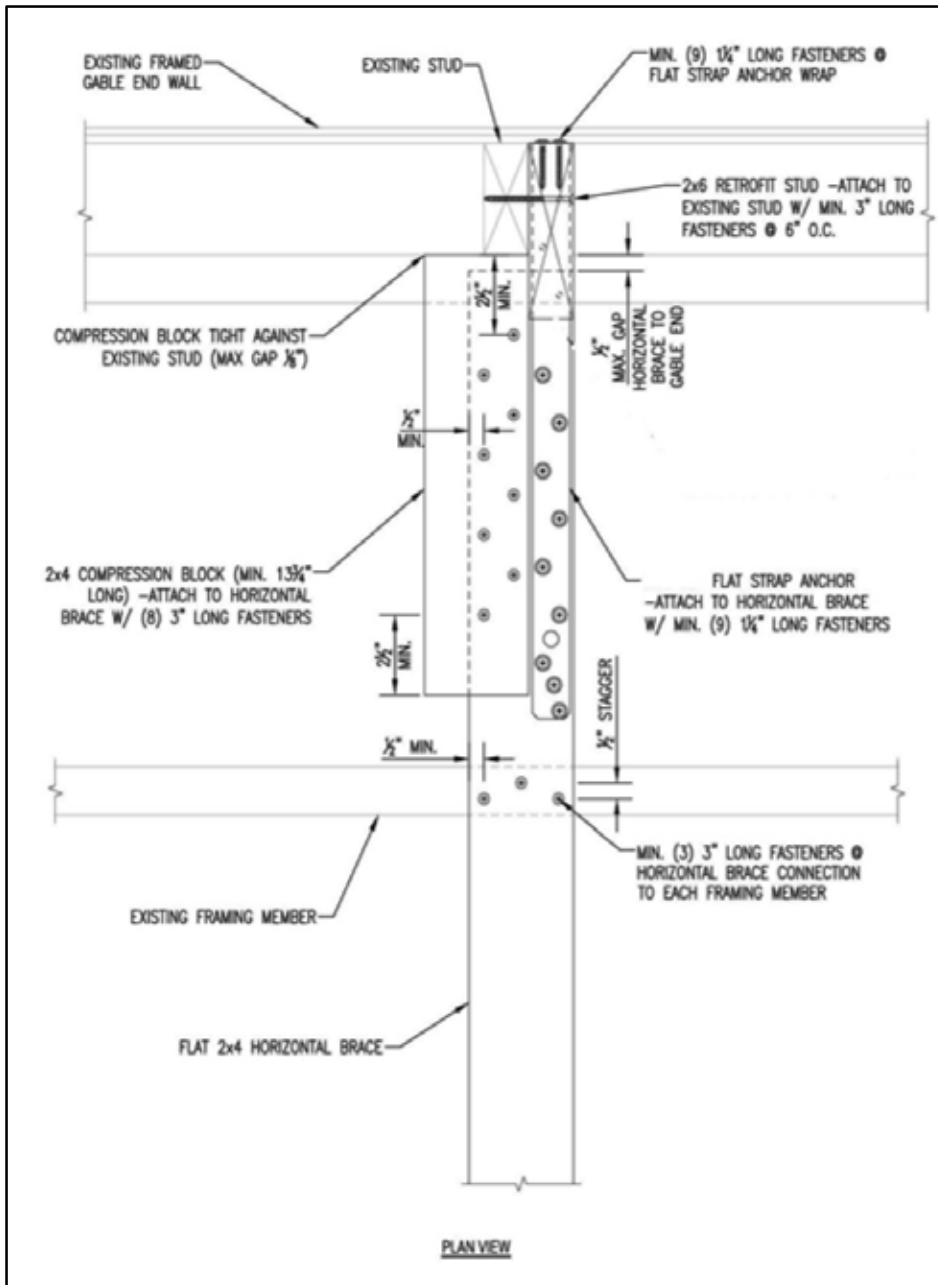

Figure A104.2.8. Details of Strap & Compression Block Installation – 2x6 Retrofit Stud

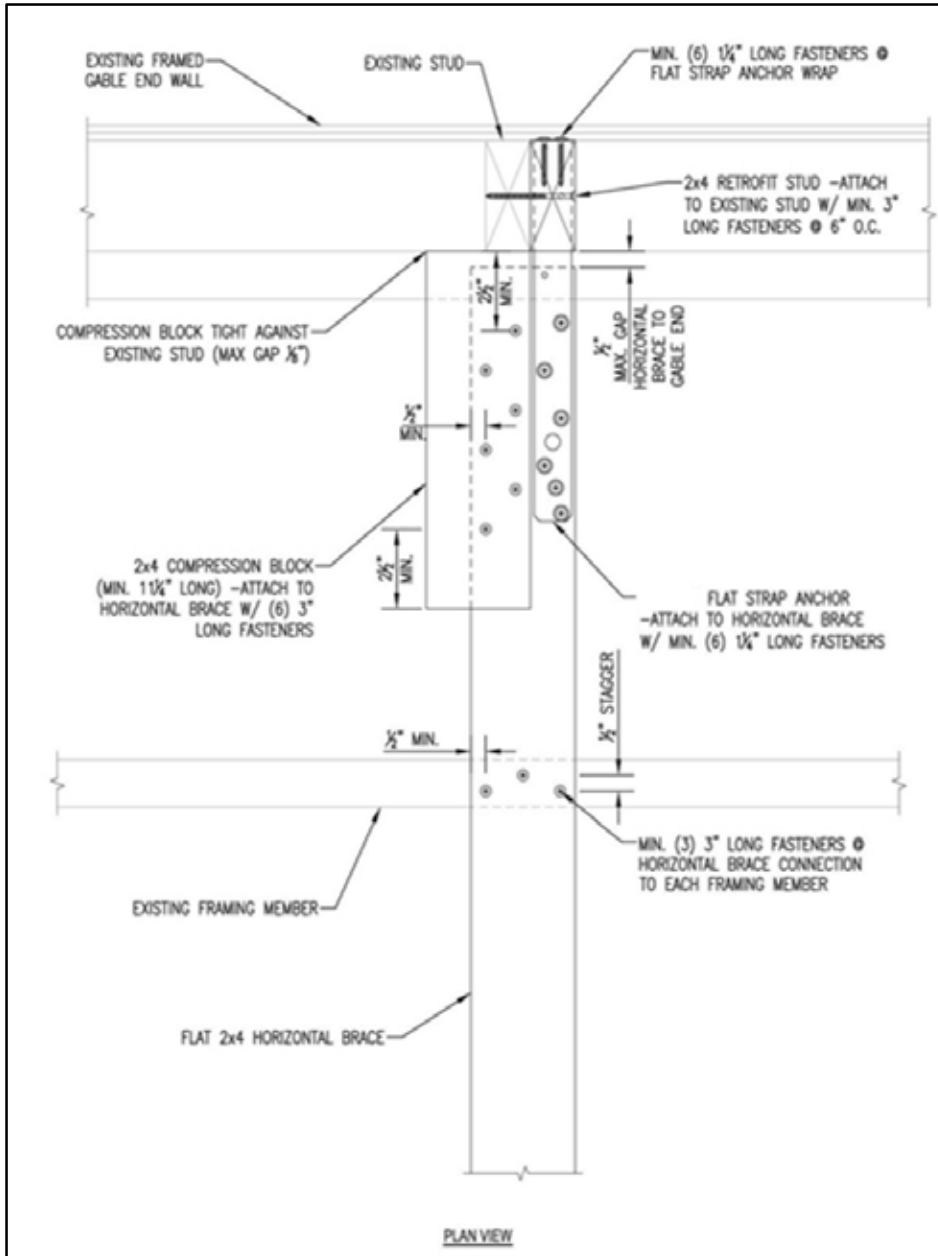

Figure A104.2.9. Details of Strap & Compression Block Installation – 2x8 Retrofit Stud

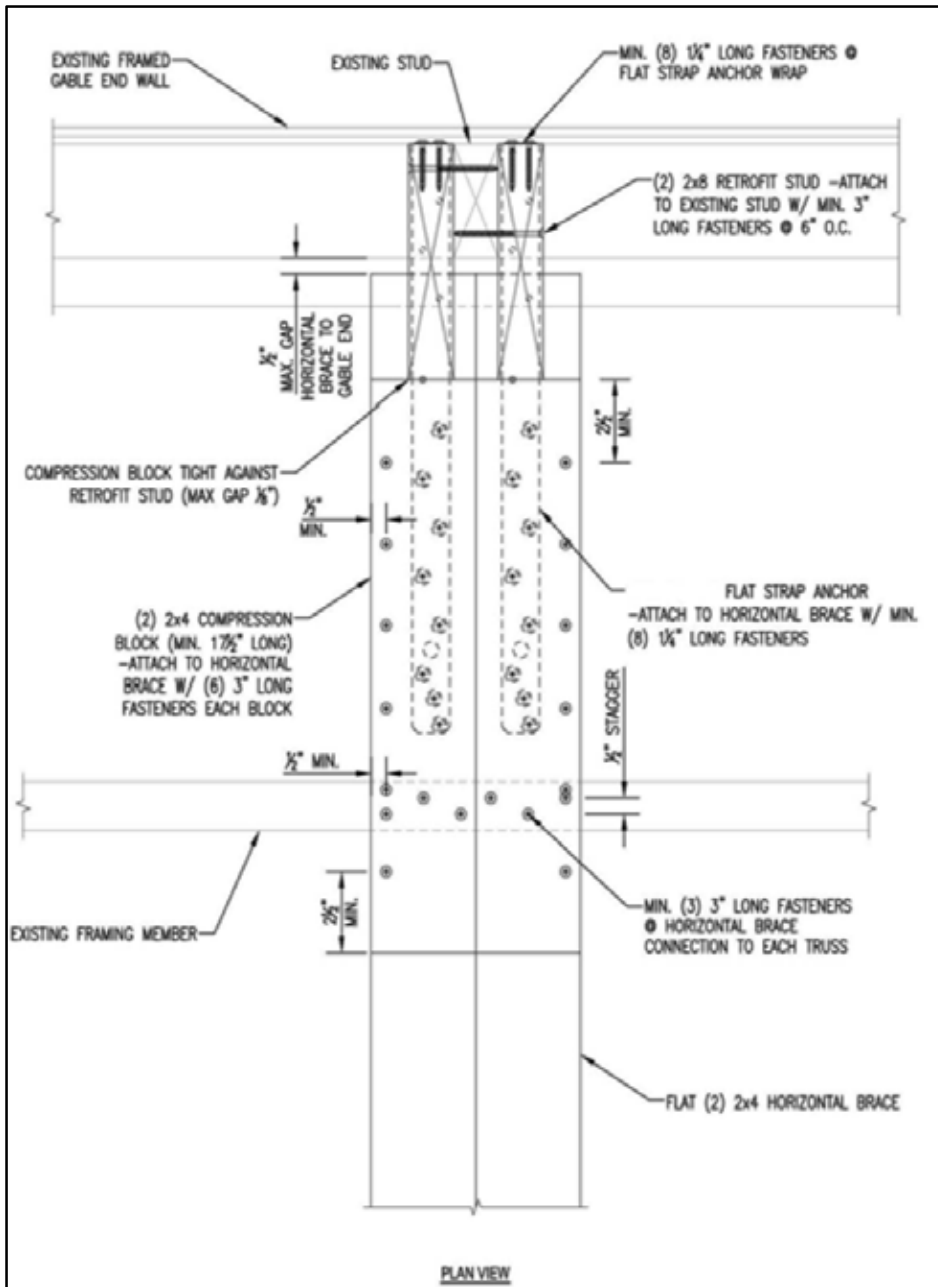

Figure A104.2.10. Details of Strap & Compression Block Installation (2) 2x8 Retrofit Stud

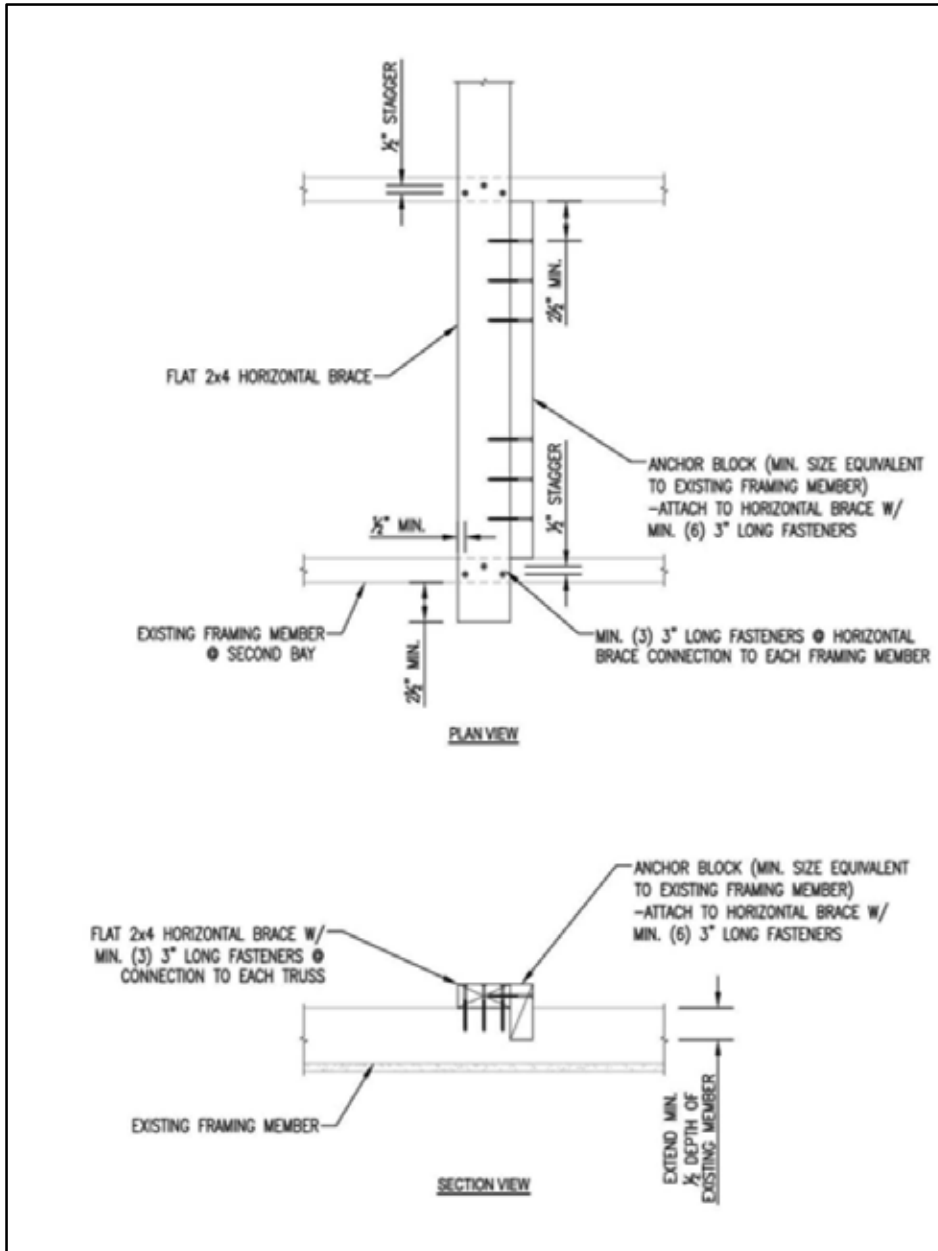

Figure A104.2.11. Details of Anchor Block Installation

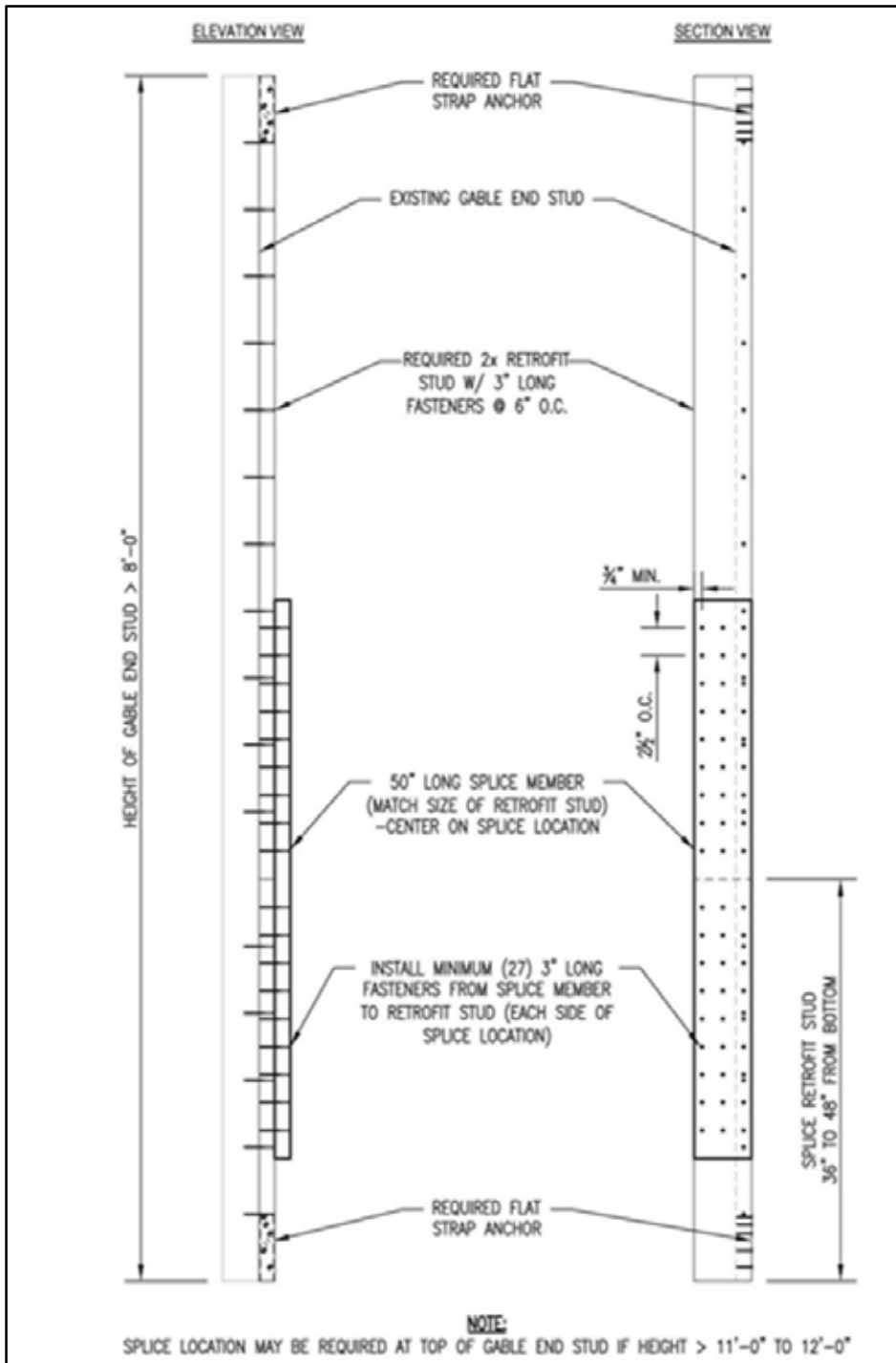

Figure A104.3. Details of Retrofit Stud Splice

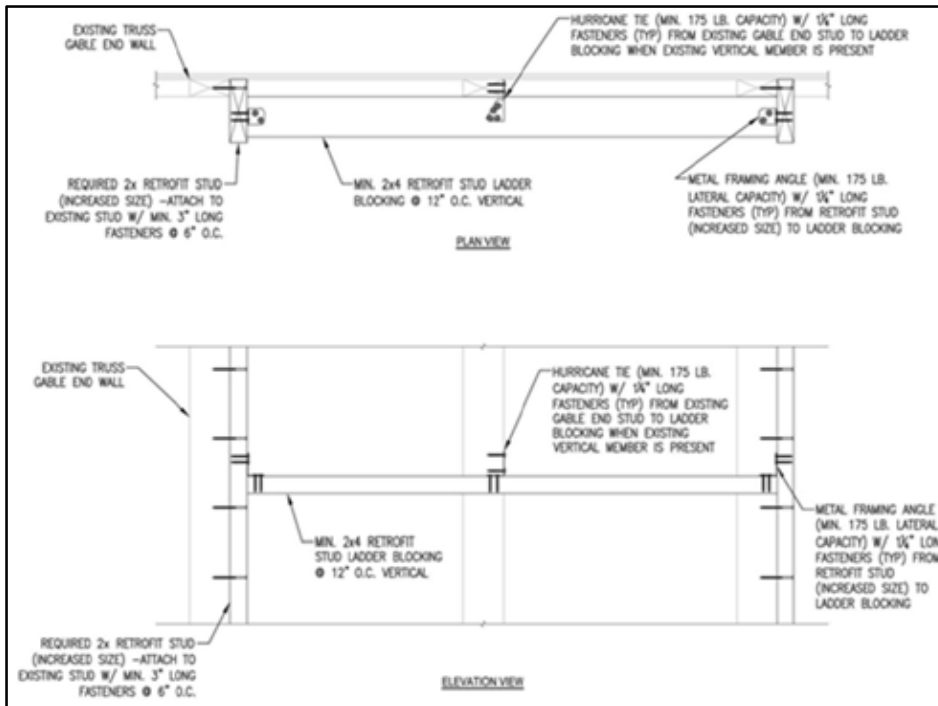

Figure A104.5.1.1. Details of Ladder Bracing for Omitted Retrofit Stud (Truss Gable End)

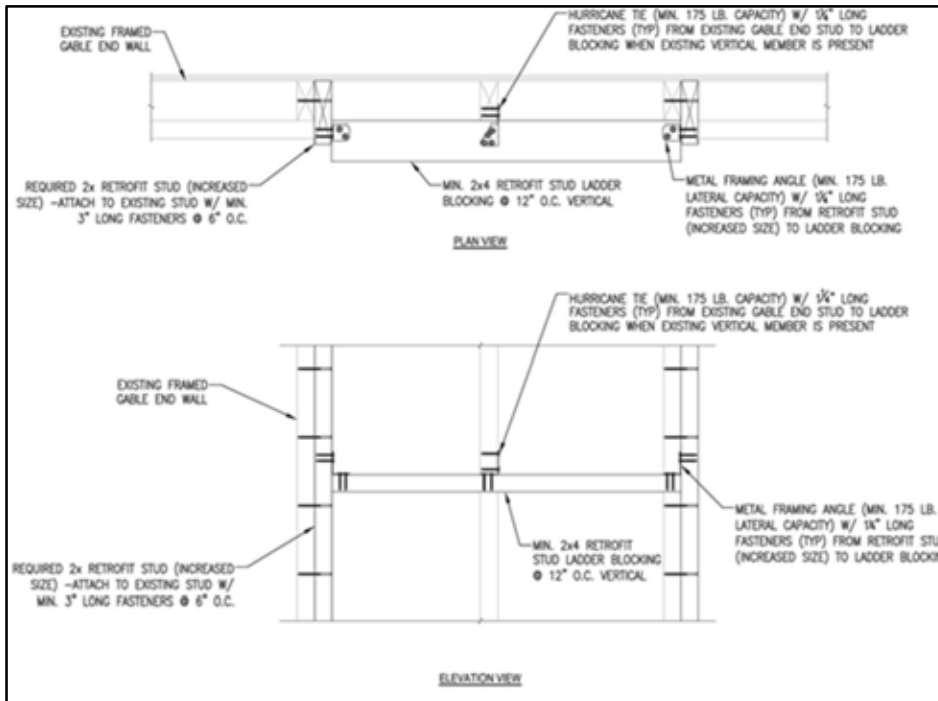

Figure A104.5.1.2. Details of Ladder Bracing for Omitted Retrofit Stud (Conventional Framing)

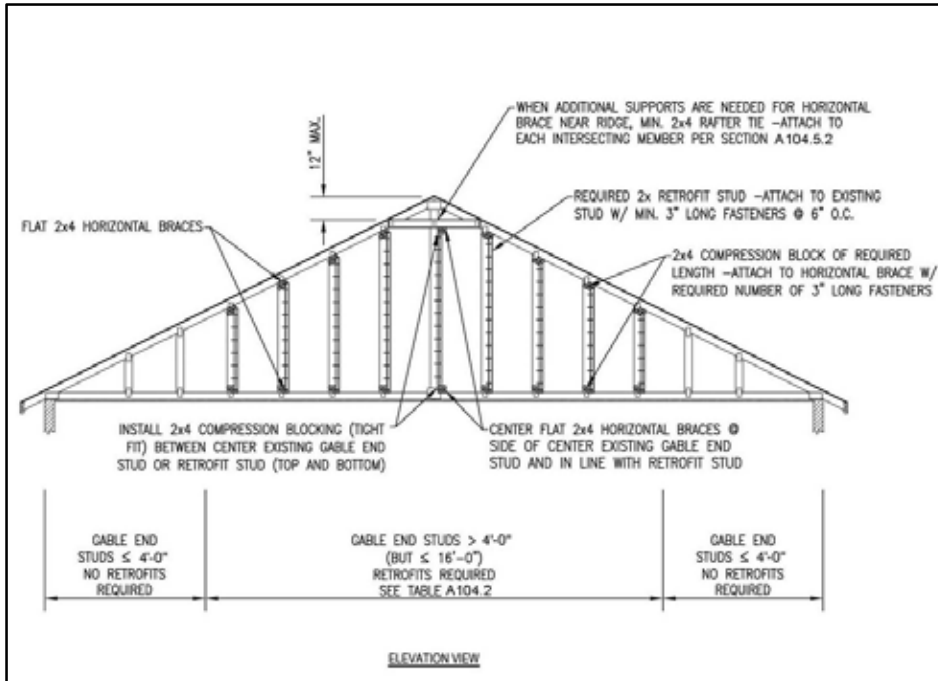

Figure A104.5.2. Details of Retrofit Ridge Tie Installation

TABLE A104.2 Gable End Retrofit Element Sizing and Fastening

Exposure	Maximum 3-Sec. Gust	Maximum Height of Gable End Stud b.			
		8'-0"	11'-3"	14'-9"	16'-0"
C	110	8'-0"	11'-3"	14'-9"	16'-0"
C	120	7'-6"	10'-6"	13'-6"	16'-0"
C	130	7'-0"	10'-0"	12'-3"	16'-0"
C	150	6'-6"	8'-9"	11'-0"	16'-0"
B	110	8'-0"	12'-3"	16'-0"	N/A c.
B	130	8'-0"	11'-3"	14'-9"	16'-0"
B	140	7'-6"	10'-6"	13'-6"	16'-0"



B	150	7'-0"	10'-0"	12'-3"	16'-0"
		Method #1	Method #2	Method #3	Method #4
		See Figures A-2 and A-7	See Figures A-3 and A-8	See Figures A-4 and A-9	See Figures A-5 and A-10
Step	Retrofit Elements				
1	Minimum size of Horizontal Brace	2x4	2x4	2x4	2 each 2x4
2	Minimum number of 3" long fasteners to connect Horizontal Brace to existing stud	3	3	3	3
3	Retrofit Stud to Minimum	2x4	2x6	2x8	2 each 2x8
4	Flat Strap Length Minimum length	21"	30"	38"	2 straps 30"
5	Minimum number of 1¼" long fasteners to connect Flat Strap to Retrofit Stud	6	9	12	8 on each strap
6	Maximum on center spacing of 3" long fasteners to connect Retrofit Stud to Existing Stud	6"	6"	6"	6"
7	Minimum number of 1¼" long fasteners to connect Strap to Retrofit Stud	6	9	12	8 on each strap

8	Compression Block Minimum length	11¼"	13¾"	16¼"	17½"
9	Minimum number of 3" long fasteners to connect Compression Block to Horizontal Brace	6	8	10	12

Interpolation between given wind speeds not permitted.

Existing gable end studs less than or equal to 3'-0" in height shall not require retrofitting.

N/A = Not Applicable. Exceeds 16'-0" maximum height.

Fasteners shall be #8 screws or 10d nails

Note: See Section A104.2 (page for definition of right angle gusset brackets).

TABLE A104.6 Spacing of Right Angle Gusset Brackets Connecting Gable End Wall to Wall Below

Exposure Category	Wind Speed, mph	Maximum Spacing of Right Angle Gusset Brackets
	Maximum 3-Sec. Gust	
C	110	38 in.
C	120	32 in.
C	130	28 in.
C	140	24 in.
C	150	20 in.
B	110	48 in.
B	120	40 in.
B	130	36 in.
B	140	30 in.
B	150	26 in.

Appendix B: Design Wind Pressures for Garage Doors

TABLE B-1. Design Wind Pressures for Garage Doors

ASCE 7-05 (ASCE 7-10) ³ Basic Wind Speed 110 mph (140 mph)	
Effective wind area (ft ²)	Design Pressure (psf)
50 (Single car)	20, -22
100 (Two car)	19, -21

Notes for Table B-1:

1. Positive pressures indicate pressure acting toward the building surface; negative pressures indicate pressure acting away from the building surface.
2. Table values shall be adjusted for height and exposure by multiplying by the adjustment coefficient in Table B-2.
3. ASCE 7-10 design wind pressures listed have already been reduced to reflect allowable stress design pressures. No further reduction allowed.

Table B-2. Height and Exposure Adjustment Coefficients for Use with Table B-1

Mean Roof Height (ft)	Exposure B	Exposure C
15	1.00	1.21
20	1.00	1.29
25	1.00	1.35
30	1.00	1.40
35	1.05	1.45



40	1.09	1.49
45	1.12	1.53
50	1.16	1.56
55	1.19	1.59
60	1.22	1.62

Extras

Disclaimer

The Insurance Institute for Business & Home Safety (IBHS) shall not be held responsible or liable for any modifications, repairs or replacements with regard to any property, systems, components, or the contents therein. IBHS is neither a guarantor nor insurer. IBHS assumes no responsibility or liability for any advice or services rendered by any builder, engineer, architect, plan reviewer, plan designer, inspector, manufacturer, or other professional as a result of the certification of such individual as a FORTIFIED Home™ Evaluator, FORTIFIED Wise™ – Associate or FORTIFIED Wise™ – Professional.

Property Owners considering designation for their homes are solely responsible for determining whether to pursue designation and should obtain any additional information necessary to make an informed decision. If the Property Owner is dissatisfied with any aspect of the FORTIFIED Home™ program, the sole and exclusive remedy is to discontinue activities relating to this program. No refunds of any fees paid will be provided by IBHS to Property Owners who fail to obtain any designation under the FORTIFIED Home™ program.

About FORTIFIED & IBHS

FORTIFIED Home™ is a service mark owned by the Institute for Business & Home Safety (IBHS) and may not be used without the express written permission of IBHS. The process for receiving a Fortified Home™ designation is governed exclusively by the guidelines developed by IBHS.

Participation in the FORTIFIED Home™ program can reduce the risk of damage to a home, but it cannot eliminate it. Residents of FORTIFIED homes should prepare for potential disasters and heed all evacuation warnings.

IBHS assumes no responsibility or liability for any advice or services rendered by any builder, engineer, architect, plan reviewer, plan designer, inspector, manufacturer, or other professional as a result of the certification of such individual as a FORTIFIED Home™ Evaluator.

Applicants considering designation for their homes are solely responsible for determining whether to pursue designation and should obtain any additional information necessary to make an informed decision. If the Applicant is dissatisfied with any aspect of the FORTIFIED Home™ program, the sole and exclusive remedy is to discontinue activities relating to this program. No refunds of any fees paid will be provided by IBHS to Applicants who fail to obtain any designation under the FORTIFIED Home™ program.



Sealed Roof Deck

Bulletin No. 2015-01

First Release:

March 19, 2015

Prepared by:

Fred Malik, Vice President,
FORTIFIED Programs

Applicable Standards:

FORTIFIED Home™–Hurricane
FORTIFIED Home™–High Wind
FORTIFIED Home™–High Wind & Hail
FORTIFIED for Safer Living™

Applicable Designation Level:



Installation of 2 Layers of #30 Felt as a Qualified Sealed Roof Deck System for Asphalt Shingle or Metal Roofing

Abstract

The installation of 2 layers of #30 roofing felt has been tested, evaluated and approved by IBHS as a qualified sealed roof deck system for asphalt shingle or metal roofing.

Requirements

- Two (2) layers of ASTM D226 Type II (#30) or ASTM D4869 Type III or Type IV (#30) underlayment shall be installed in a shingle fashion, lapped 19 in. on horizontal seams (36-in. roll), and 6 in. on vertical seams.
 - **NOTE:** Be sure to check product labeling carefully. Not all products labeled ASTM D4869 are Type III or Type IV. Look for ASTM D4869 felt that is labeled Type III or Type IV. ASTM D4869 Type I or Type II will **NOT** be accepted.
- Installation of first course of felt to be installed as described below and shown in Figure 1.
 - Cut 17 in. off one side of the roll and install the remaining 19-in.-wide strip of underlayment* along the eave. Safely tack in place. Carefully install a 36-in.-wide roll of underlayment* over the 19-in.-wide course of underlayment along the eave. Follow the same procedure for each, overlapping the sheets 19 in. (leaving a 17-in. exposure). Fasten with one row in the field of the sheet at 12 in. o.c. and one row at the overlaps fastened 6 in. o.c.
- Fasten underlayment at approximately 6 in. o.c. along the laps and at approximately 12 in. o.c. in the field of the sheet between the side laps.
 - For design wind speeds less than 140 mph (ASCE 7-05): secure underlayment using annular ring or deformed shank nails with 1-in.-diameter caps (button cap nails).

*Must use ASTM D226 Type II (#30) or ASTM D4869 Type III or Type IV (#30) underlayment.

Sealed Roof Deck

Bulletin No. 2015-01

First Release:

March 19, 2015

Prepared by:

Fred Malik, Vice President,
FORTIFIED Programs

Applicable Standards:

- FORTIFIED Home™–Hurricane
- FORTIFIED Home™–High Wind
- FORTIFIED Home™–High Wind & Hail
- FORTIFIED for Safer Living™

Applicable Designation Level:



- For design wind speeds 140 mph or greater (ASCE 7-05): secure underlayment using annular ring or deformed shank nails with thin metal disks (“tincaps”).

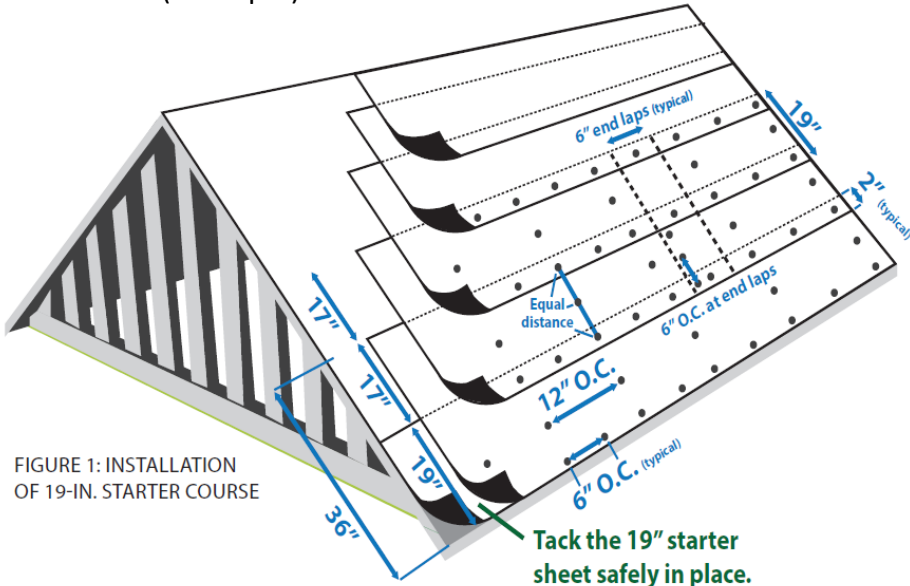

FIGURE 1: INSTALLATION OF 19-IN. STARTER COURSE

Compliance Verification Requirements

This method of sealing the roof deck is to be documented and verified by a certified FORTIFIED evaluator. Acceptable documentation includes but is not limited to: pictures of laps and fasteners at 4 different locations of the roof; a completed Roof Compliance Form (RCF-1); certification by the installer; bills of lading; invoices; and product packaging.

Completing Evaluation Form (For FORTIFIED Evaluators Only)

On the evaluation form, in the “Sealed Roof Deck” section, for question SRD System Type, select “Other” (see Figure 2 below). It will be necessary to provide documentation as described above.



Figure 2. Evaluation Form; Section—Sealed Roof Deck; Question—SRD System Type?



Sealed Roof Deck

Material Options for Taping Roof Deck Seams

Bulletin No. 2015-02

First Release:

July 31, 2015

Prepared by:

Fred Malik, Vice President,
FORTIFIED Programs

Applicable Standards:

- FORTIFIED Home™–Hurricane
- FORTIFIED Home™–High Wind
- FORTIFIED Home™–High Wind & Hail
- FORTIFIED for Safer Living™

Applicable Designation Level:



Abstract

The material options for taping the seams of the roof deck have been expanded to include AAMA 711-13, Level 3 (for exposure up to 80°C/176°F).

Requirements

There are two material options for taping the seams on the roof deck.

Option 1

Apply an ASTM 1970 compliant self-adhering polymer-modified bitumen flashing tape, at least 4-in. wide, directly to the roof deck to seal the horizontal and vertical joints in the roof deck.

Option 2

Apply an AAMA 711-13, Level 3 (for exposure up to 80°C/176°F) compliant self-adhering flexible flashing tape, at least 3¼-in. wide, directly to the roof deck to seal the horizontal and vertical joints in the roof deck.

Any flashing tape used to achieve a sealed roof deck must be fully adhered without voids (e.g., wrinkles) in order to be accepted. In some instances, the ability of self-adhered flashing tapes to adhere to Oriented Strand Board (OSB) sheathing may be compromised by the level of surface texture or the wax used to improve the water resistance of the OSB panel. In applications where flashing tape adhesion to OSB is marginal, apply a manufacturer-specified compatible primer to the OSB panels where the tape will be applied to ensure the proper attachment of the self-adhering tape to the sheathing. Do not nail or staple the tape to the roof sheathing. Refer to the manufacturer’s recommendations for installation and primer requirements (if applicable). Next, apply a code-compliant #30 ASTM D226 Type II or ASTM D4869 Type IV underlayment over the self-adhering tape. This underlayment must be attached using annular ring or

Sealed Roof Deck

Bulletin No. 2015-02

First Release:

July 31, 2015

Prepared by:

Fred Malik, Vice President,
FORTIFIED Programs

Applicable Standards:

- FORTIFIED Home™–Hurricane
- FORTIFIED Home™–High Wind
- FORTIFIED Home™–High Wind & Hail
- FORTIFIED for Safer Living™

Applicable Designation Level:



Note: Although 4 photographs is the minimum number of pictures required, the goal is to achieve a 360° view of the house and FORTIFIED upgrades. Most photographs will be taken from the ground and site conditions may dictate that more than the minimum be provided.

deformed shank roofing fasteners with minimum 1-in.-diameter caps (button cap nails) at 6 in. o.c. spacing along all laps and at 12 in. o.c. in the field or a more stringent fastener schedule if required by the manufacturer for high-wind and prolonged exposure installations. Horizontal laps must be a minimum of 2 in. and end laps must be a minimum of 6 in.

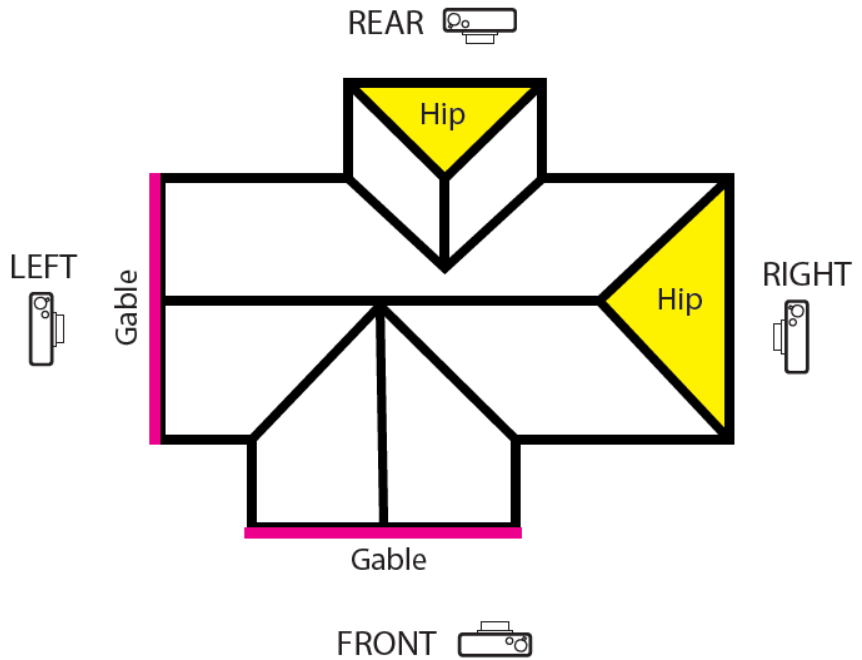

Figure 0-1. Minimum photograph requirement and locations (Front, Rear, Left and Right).

Compliance Verification Requirements

This method of sealing the roof deck is to be documented and verified by a certified FORTIFIED Evaluator. Acceptable documentation includes, but is not necessarily limited to:

Pictures of Tape Installed

Count: Minimum = 4

- Must show 4 different sections of the roof (Front, Rear, Left and Right). See Fig. 0-1.
- Must clearly show tape fully adhered to the deck without wrinkles or voids. See Fig. 0-2.
- Must show at least one full sheet of roof decking (with all 4 seams taped) per photo.
- Must be in focus.

Sealed Roof Deck

Bulletin No. 2015-02

First Release:

July 31, 2015

Prepared by:

Fred Malik, Vice President,
FORTIFIED Programs

Applicable Standards:

FORTIFIED Home™–Hurricane
FORTIFIED Home™–High Wind
FORTIFIED Home™–High Wind & Hail
FORTIFIED for Safer Living™

Applicable Designation Level:



- Must have the following clearly visible: date, address or FORTIFIED ID, location (e.g., Front, Rear, Left and Right). See Fig. 0-3.

Pictures of Felt Installed

Count: Minimum = 4

- Must show 4 different sections of the roof (Front, Rear, Left and Right).
- Must clearly show laps and fasteners.
- Must have the following clearly visible: date, address or FORTIFIED ID, location (e.g., Front, Rear, Left and Right).

Other Documentation Required

- Completed Roof Compliance Form (RCF-1) identifying tape manufacturer, specification requirement (ASTM 1970 or AAMA 711-13, Level 3) and type of compatible primer, if used.

OR

- Invoices and product packaging identifying tape product name, manufacturer, specification requirement (ASTM 1970 or AAMA 711-13, Level 3) and type of compatible primer, if used.



Figure 0-2. Applying qualified tape to roof deck seams using flat blade to eliminate voids and wrinkles.

Sealed Roof Deck

Bulletin No. 2015-02

First Release:

July 31, 2015

Prepared by:

Fred Malik, Vice President,
FORTIFIED Programs

Applicable Standards:

- FORTIFIED Home™–Hurricane
- FORTIFIED Home™–High Wind
- FORTIFIED Home™–High Wind & Hail
- FORTIFIED for Safer Living™

Applicable Designation Level:

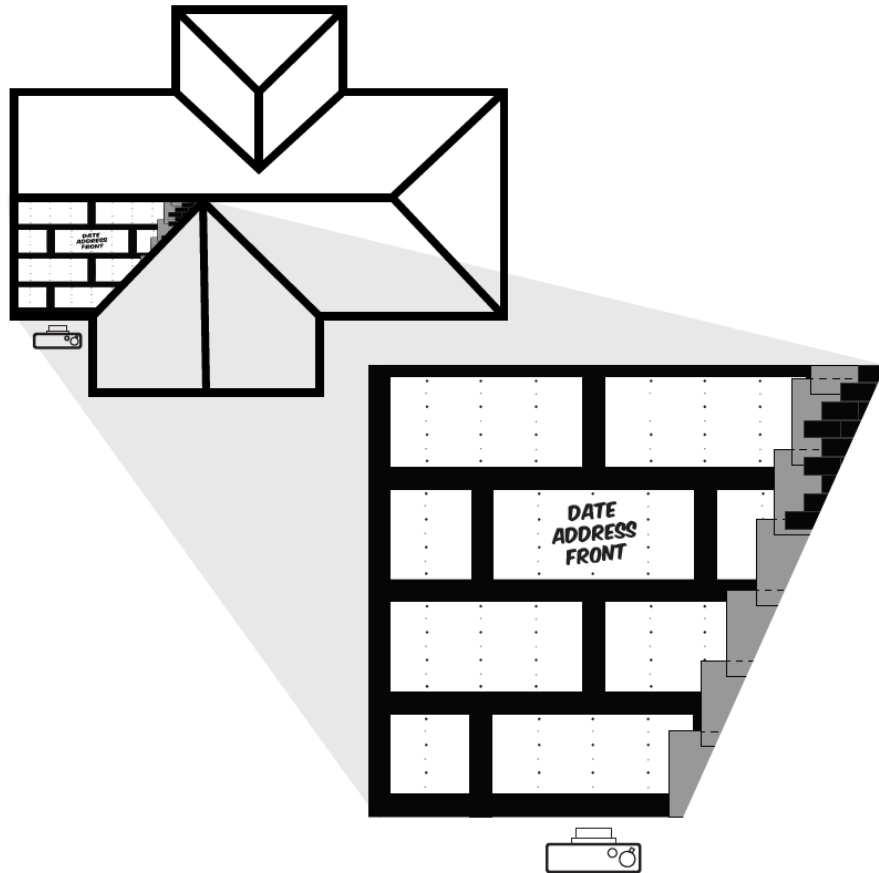

Figure 0-3. Labeling of roof deck to identify project and photo location.

Completing Evaluation Form

When completing the Sealed Roof Deck section of a FORTIFIED Home Evaluation form, select SRD System Type as shown in Fig. 0-4. Add photos and other documentation by clicking on the camera icon.

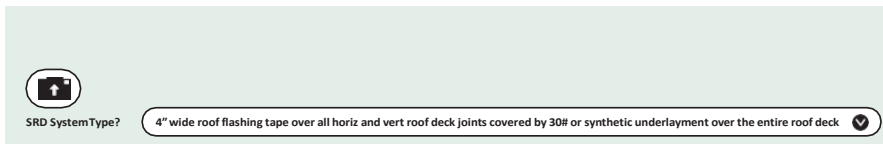

Figure 0-4. Selection for SRD system type.



Garage Doors

Bulletin No. 2015-03

First Release:

September 25, 2015

Prepared by:

Fred Malik, Vice President,
FORTIFIED Programs

Applicable Standards:

FORTIFIED Home™–High Wind
FORTIFIED Home™–High Wind & Hail
FORTIFIED for Safer Living™

Applicable Designation Level:

Garage Door Pressure Rating Requirements in High Wind–Prone Areas

Abstract

Garage doors cover the largest openings in the building envelope. It is important to ensure each garage door has an adequate design pressure rating for the site conditions. This bulletin provides information on how to specify and verify the design pressure ratings for garage doors installed on homes located in areas that use the FORTIFIED Home™–High Wind and FORTIFIED Home™–High Wind & Hail standards.

Requirements

Garage doors must be tested and approved in accordance with, at a minimum, International Residential Code (IRC) accepted design pressure test standards for a $V_{asd} = 110$ mph 3-second gust ($V_{ult} = 140$ mph) design wind speed (or with locally adopted standards if they are more restrictive). Acceptable IRC design pressure test standards include ANSI/DASMA 108 or ASTM E330 (products must be tested to 1.5 times design pressure). The Florida Building Code Testing Application Standard, TAS 202, is also acceptable for the FORTIFIED Home™ program.

Design pressure values for garage doors vary depending on the size of the doors, exposure category and mean roof height of the building. The required design pressures can be found in the tables below.

Exposure B is for homes located in neighborhoods surrounded by other buildings and/or trees.

Exposure C is for homes located in more exposed settings with few buildings and/or there are large open areas (including but not limited to fields, lakes, rivers, and golf courses) adjacent to the home site.



Garage Doors

Bulletin No. 2015-03

First Release:

September 25, 2015

Prepared by:

Fred Malik, Vice President,
FORTIFIED Programs

Applicable Standards:

FORTIFIED Home™–High Wind
FORTIFIED Home™–High Wind & Hail
FORTIFIED for Safer Living™

Applicable Designation Level:



Note: Care should be taken when specifying and ordering garage doors. Many times, multiple door configurations (width, height, design pressure ratings, windows, etc.) can be shown on a single engineered drawing included in manufacturer documentation. Be sure the door installer quotes and installs the door with the correct track, and correct number of rollers and struts to achieve the appropriate design pressure ratings described above. If the door manufacturer does not have design pressure rating information for a door that is specified or installed at the subject property, the door will not meet FORTIFIED requirements.

Table 1. Height & Exposure Adjusted Design Pressures for Single Garage Doors

Mean Roof Height (ft)	Single Car		Single Car	
	Exposure B		Exposure C	
	+	-	+	-
15	20	-22	24	-27
20	20	-22	26	-28
25	20	-22	27	-30
30	20	-22	28	-31
35	21	-23	29	-32
40	22	-24	30	-33
45	22	-25	31	-34
50	23	-26	31	-34
55	24	-26	32	-35
60	24	-27	32	-36

Table 2. Height & Exposure Adjusted Design Pressures for Double Garage Doors

Mean Roof Height (ft)	Two Car		Two Car	
	Exposure B		Exposure C	
	+	-	+	-
15	19	-21	23	-25
20	19	-21	25	-27
25	19	-21	26	-28
30	19	-21	27	-29
35	20	-22	28	-30
40	21	-23	28	-31
45	21	-24	29	-32
50	22	-24	30	-33
55	23	-25	30	-33
60	23	-26	31	-34



Garage Doors

All installations must be in accordance with the manufacturer's instructions.

Bulletin No. 2015-03

First Release:

September 25, 2015

Prepared by:

Fred Malik, Vice President,
FORTIFIED Programs

Applicable Standards:

- FORTIFIED Home™–High Wind
- FORTIFIED Home™–High Wind & Hail
- FORTIFIED for Safer Living™

Applicable Designation Level:



Compliance Verification Requirements

It is not possible to determine the design pressure ratings of a garage door simply by looking at the door or the track. If the door has a design pressure label, which is not common, (see Fig. 0-1 and Fig. 0-2 below) and the design pressures listed meet the criteria above, the door should meet FORTIFIED Home™ requirements.

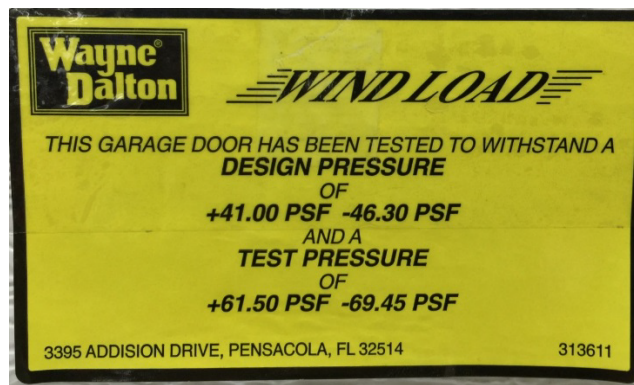

Figure 0-1



Figure 0-2



Garage Doors

Bulletin No. 2015-03

First Release:

September 25, 2015

Prepared by:

Fred Malik, Vice President,
FORTIFIED Programs

Applicable Standards:

FORTIFIED Home™–High Wind

FORTIFIED Home™–High Wind & Hail

FORTIFIED for Safer Living™

Applicable Designation Level:



Note: Although 3 is the minimum number of photographs required, the goal is to achieve a complete view of each garage door. Photographs must be taken from inside the garage with the garage door closed. Site conditions may dictate that more than the minimum be provided.

Any door that is not labeled or does not have paperwork that indicates its design pressure ratings meet those outlined above will be deemed not to meet FORTIFIED Home™ requirements. Any door that is labeled, or has documentation but does not meet the design pressure criteria provided above, will need to be retrofitted to meet these pressure requirements or replaced. If the door is retrofitted, documentation will be required certifying the retrofitted door, hardware, tracks and anchorage match those for a new door from the manufacturer that meets the pressure requirements given above.

Acceptable documentation includes, but is not necessarily limited to:

Pictures of all Garage Doors

Minimum = 3: 1 of track on each side, 1 of entire door, plus 1 close up of any label that identifies door manufacturer, model and/or design pressure rating, if applicable.

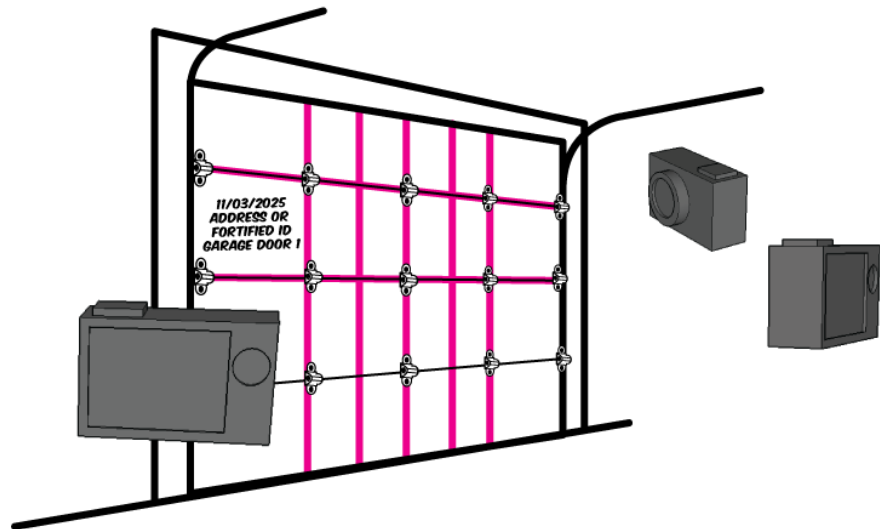

Figure 0-3. Minimum photograph requirement and locations. Labeling of garage door to identify project and photo location.



Garage Doors

Bulletin No. 2015-03

First Release:

September 25, 2015

Prepared by:

Fred Malik, Vice President,
FORTIFIED Programs

Applicable Standards:

FORTIFIED Home™–High Wind

FORTIFIED Home™–High Wind & Hail

FORTIFIED for Safer Living™

Applicable Designation Level:



- Pictures should be taken of each door while closed and from inside the garage.
- Pictures must be in focus.
- Pictures must have the following clearly visible: Date, Address or FORTIFIED ID, Door ID (e.g., Garage Door 1, Garage Door 2, etc.). See Figure 0-3.

Other Required Documentation

- Invoices and/or product packaging identifying garage door product name, manufacturer, and design pressure rating
- Documentation from Miami-Dade, FBC, TDI product approvals or ICC Evaluation Reports, if applicable

Completing Evaluation Form

(For FORTIFIED Evaluator)

When completing a FORTIFIED Home™ evaluation form, under Section: Garage Doors, enter:

- Garage door size
- Positive design pressure
- Negative design pressure

Bulletin No. 2015-04

First Release:

October 13, 2015

Prepared by:

Fred Malik, Vice President,
FORTIFIED Programs

Applicable Standards:

FORTIFIED Home™–Hurricane
FORTIFIED Home™–High Wind
FORTIFIED Home™–High Wind & Hail
FORTIFIED for Safer Living®

Applicable Designation Level:



Using 2-Part Closed-Cell Foam Adhesive

Abstract

Strengthening the attachment of roof sheathing and installation of a sealed roof deck system can be achieved simultaneously by applying an ASTM or TAS tested two-part, spray polyurethane foam adhesive to the underside of the roof deck as shown in Figure 1.

This system can satisfy two FORTIFIED Home™–Bronze requirements:

1. Sealing the roof deck.
2. Supplemental deck attachment, when the roof deck is fastened with staples, 6d common nails or 8d common nails at 12 in. on center in the field.



Figure 1. Closed-cell polyurethane foam adhesive applied to the underside of the roof sheathing at the joints between the sheathing panels and along all intersections between roof sheathing and all roof framing members.



Sealed Roof Deck Supplemental Deck Attachment

Bulletin No. 2015-04

First Release:

October 13, 2015

Prepared by:

Fred Malik, Vice President,
FORTIFIED Programs

Applicable Standards:

FORTIFIED Home™–Hurricane
FORTIFIED Home™–High Wind
FORTIFIED Home™–High Wind & Hail
FORTIFIED for Safer Living®

Applicable Designation Level:



Requirements

A 2-part closed-cell foam polyurethane adhesive can be used on new or existing homes. This system is most commonly used on existing homes where the roof cover is deemed to be in good condition and NOT in need of replacement. When the roof cover is not being replaced, other systems that are installed from the topside cannot be used. Spray foam allows for improvements to be made from within the attic. This system can be used to satisfy two FORTIFIED Home™–Bronze requirements:

1. Sealing the roof deck.
2. Supplemental deck attachment, when the roof deck is fastened with staples, 6d common nails or 8d common nails at 12 in. on center in the field.

The minimum requirements for spray adhesives are:

- Product must be tested and evaluated in accordance with either ASTM E330, Standard Test Method for Structural Performance of Exterior Windows, Doors, Skylights and Curtain Walls by Uniform Static Air Pressure Difference (applied to roof sheathing), or TAS 202-94, Criteria for Testing Impact and Non- Impact Resistant Building Envelope Components Using Uniform Static Air Pressure. The minimum allowable Design Uplift Pressure must be greater than or equal to those listed below.
 - FORTIFIED Home™–Hurricane: at least 110 psf (proof test of at least 165 psf)
 - FORTIFIED Home™–High Wind: at least 80 psf (proof test of at least 120 psf)
 - FORTIFIED Home™–High Wind & Hail: at least 80 psf (proof test of at least 120 psf)
- Two-component spray polyurethane foam system with a minimum core density of 1.5–3.0 pcf in accordance with ASTM D1622, Standard Test Method for Apparent Density of Rigid Cellular Plastics.
- Spray polyurethane foam adhesive system must be installed by a properly trained and qualified applicator in accordance with the manufacturer’s maintenance and installation guidelines.



Sealed Roof Deck Supplemental Deck Attachment

Bulletin No. 2015-04

First Release:

October 13, 2015

Prepared by:

Fred Malik, Vice President,
FORTIFIED Programs

Applicable Standards:

FORTIFIED Home™–Hurricane
FORTIFIED Home™–High Wind
FORTIFIED Home™–High Wind & Hail
FORTIFIED for Safer Living®

Applicable Designation Level:



Note: In order for this method to be accepted for sealing the roof deck and for adding supplemental roof deck attachment, access to the entire underside of the roof deck within the attic must be available. If the slope of the roof is low, such that eaves are inaccessible, or any portion of the underside of the deck is obstructed by equipment or ductwork, or is otherwise inaccessible, it will be necessary to use an alternative qualified method to seal the portion of the deck that is unreachable by the spray foam installer.

To provide enhanced roof sheathing attachment and to seal the roof deck, apply a 1.5- to 3-in. fillet of 2-part spray-applied polyurethane foam adhesive to:

- All joints between sheathing
- All intersections between roof sheathing and roof framing members
- All valleys

Use the minimum density and installation requirements prescribed by the manufacturer to meet a minimum Design Uplift Pressure on the sheathing of 80 psf or 110 psf; as appropriate to the applicable standard.

All installations must be in accordance with the manufacturer’s instructions.

Compliance Verification Requirements

It is not possible to determine the chemistry of a spray foam product by visual inspection. Therefore, it is necessary to collect documentation from the installing contractor identifying the manufacturer and product used for the improved roof sheathing attachment/sealed roof deck.

Documentation must be provided to the Certified FORTIFIED Home™ Evaluator and be included with the FORTIFIED Home evaluation checklist. Documentation must state the installation meets the manufacturer’s requirements for an allowable Design Uplift Pressures detailed below.

- FORTIFIED Home™–Hurricane: at least 110 psf (proof test of at least 165 psf)
- FORTIFIED Home™–High Wind: at least 80 psf (proof test of at least 120 psf)
- FORTIFIED Home™–High Wind & Hail: at least 80 psf (proof test of at least 120 psf)



Sealed Roof Deck Supplemental Deck Attachment

Bulletin No. 2015-04

First Release:

October 13, 2015

Prepared by:

Fred Malik, Vice President,
FORTIFIED Programs

Applicable Standards:

FORTIFIED Home™–Hurricane
FORTIFIED Home™–High Wind
FORTIFIED Home™–High Wind & Hail
FORTIFIED for Safer Living®

Applicable Designation Level:



Note: Although 4 photographs is the minimum number of pictures required, the goal is to achieve a complete view of the underside of the roof deck. Photographs must be taken from inside the attic and show product installed in accordance with the requirements listed above. Site conditions may dictate that more than the minimum be provided.

Minimum Documentation Required

- Letter from installing contractor, on company letterhead, that the material was applied by a trained installer and the installation meets the manufacturer’s requirements for an allowable Design Uplift Pressure specified for the appropriate standard.
- Documentation from Miami-Dade, FBC, TDI product approvals or ICC Evaluation Reports, if applicable (invoices and/or product labels identifying product name and manufacturer may be substituted in the absence of product test documents).
- A minimum of 4 photos of the material applied to the entire underside of the roof deck. Pictures must be taken at 4 different locations of the attic to show complete coverage.

Completing Evaluation Form

(For FORTIFIED Evaluator)

Entering Supplemental Deck Attachment

Section: Roof Deck

First, identify type of attic accessibility.

Attic accessibility

Next, indicate qualified supplemental documentation is installed. Select closed-cell foam adhesive and upload documentation.

Is qualified supplemental deck attachment installed? Yes

What type of supplemental deck attachment is installed?

Entering the SRD System Type

Section: Sealed Roof Deck

Select a closed-cell foam applied along all roof framing members and over all horizontal roof deck seams. Upload documentation.

SRD System Type?



Eligible Dwellings

FORTIFIED Home™ Dwelling Type Eligibility Requirements

Bulletin No. 2016-01

First Release:

March 4, 2016

Prepared by:

Remington Brown,
Senior Engineering Director

Applicable Standards:

- FORTIFIED Home™–Hurricane
- FORTIFIED Home™–High Wind
- FORTIFIED Home™–High Wind & Hail
- FORTIFIED for Safer Living®

Applicable Designation Level:



Abstract

The purpose of this document is to provide specific information about the type of residential building that is eligible for designation consideration in the FORTIFIED Home™ program.

Introduction

The goal of IBHS FORTIFIED Home™ program is to strengthen homes against specific natural hazards using system-based resilience upgrades and a comprehensive verification process. “Home” or “dwelling” encompasses a broad category of residential buildings. This technical bulletin defines the specific types of residential buildings that are eligible for consideration in the FORTIFIED Home™ program.

Eligibility

Qualifying Homes—Dwelling Type

1. Single-family detached homes
2. Two-family dwelling units (duplex)
3. (HUD) manufactured homes
4. Townhouses

Definitions and Conditions

1. **Single-family detached home**—a freestanding residential building occupied by one family. Limited to three stories above grade. This also includes detached single-family factory-built modular homes that are designed, built and sited to meet all local building codes.
2. **Two-family dwelling units (duplex)**—a freestanding residential building occupied by two families. Limited to three stories above grade. Note: The entire two-family building, which includes both dwelling units under consideration, must be evaluated under the appropriate FORTIFIED Home™ requirements. Individually evaluated



Eligible Dwellings

Bulletin No. 2016-01

First Release:

March 4, 2016

Prepared by:

Remington Brown,
Senior Engineering Director

Applicable Standards:

- FORTIFIED Home™–Hurricane
- FORTIFIED Home™–High Wind
- FORTIFIED Home™–High Wind & Hail
- FORTIFIED for Safer Living®

Applicable Designation Level:



units are NOT eligible for designation outside of the entire building being designated.

- (HUD) manufactured homes**—a single-family residential home manufactured to HUD’s Manufactured Home Construction and Safety Standards. Must be sited on a permanent foundation. HUD manufactured homes built before July 1994 are NOT eligible.
- Townhouse**—a single-family dwelling unit constructed in a group of three or more attached units in which *each unit extends from foundation to roof and has a yard or public way on not less than two sides*. Limited to three stories above grade. Mixed use (commercial and residential) buildings are NOT eligible. Note: The entire townhouse building, which includes all townhouse units under consideration, must be evaluated under the appropriate FORTIFIED Home™ requirements. Individually evaluated townhouse units are NOT eligible for designation outside of the entire building being designated. Example: A four-unit, two-story townhouse with all units attached is eligible for FORTIFIED only if the entire building, including each and every townhouse unit, is evaluated.

Completing Evaluation Forms

(For the FORTIFIED Evaluator)

Address Entry in Evaluation Application

When completing the FORTIFIED Home Evaluation Application for two-family dwelling units (duplex) or townhouses, list all dwelling unit addresses for the entire building under consideration on the Property Address lines. The example below lists four address numbers for a four-unit townhouse.



Eligible Dwellings

Bulletin No. 2016-01

First Release:

March 4, 2016

Prepared by:

Remington Brown,
Senior Engineering Director

Applicable Standards:

- FORTIFIED Home™–Hurricane
- FORTIFIED Home™–High Wind
- FORTIFIED Home™–High Wind & Hail
- FORTIFIED for Safer Living®

Applicable Designation Level:



FORTIFIED Home Evaluation Application

Choosing to have a FORTIFIED Home™ evaluation conducted is important to understanding where your home is vulnerable to severe weather. A FORTIFIED Home is more resistant to damage from high winds and wind-driven rain common in thunderstorms, tropical storms, hurricanes and hailstorms. With three levels of FORTIFIED designation available: Bronze, Silver and Gold, you can choose a level of protection best suited to your budget and resilience goals. Take the first step and complete the FORTIFIED application below. Fields marked with an (*) are required.

1. Applicant Information

*I am :

*Application Type :

4. Property Information

*Estimated year your home was built?

3. Property Address

*Address Line1 :

Address Line2 :

*City :

*State :

*ZIP / Postal Code :

*Country :

2. Property Owner's Name

*Title :

*First Name :

*Last Name :

*HomeOwner Email :

*Confirm HomeOwner Email :

3. Property Address

*Address Line1 :

Address Line2 :

*City :

*State :

*ZIP / Postal Code :

*Country :

*Which FORTIFIED Home program are you interested in?

*Which level of FORTIFIED designation are you interested in achieving?

Figure 1. Application indicating four addresses for a four-unit townhouse.

Dwelling Type Entry in Evaluator Checklist

Figure 2 shows dwelling type options available on the Evaluator Checklist. This drop-down menu can be found in the General/Site Information section.

FORTIFIED HOME™
Where building safety research leads to real-world solutions.

IBHS Home My Evaluations Reports New Application Library Alerts

Section Navigation Menu Section Help Save Save & Exit Validation Error(s) FEH0000000000000000 General Site Information Evaluation In Progress

Dwelling Type: (Dropdown menu open showing: Single-family detached, Duplex, Townhouse, Manufactured Home)

Exposure Category:

Finished Elevation Photos:

Year Built:

How was year built determined?

Building Height (to the nearest foot):

Is structure supported by dry stack or unreinforced foundation?

Is documentation of current termite bond or inspection available?

Was termite bond or inspection issued/performed within past 12 months?

Wind Speed (ASCE 7-05):

Figure 2. FORTIFIED Home Evaluator Checklist indicating dwelling type options.



Eligible Dwellings

Designation Certificates

Designation certificates will be issued based on verification of the appropriate FORTIFIED requirements and will list a single address for single-family detached homes. Two-family homes (duplex) and townhouse designation certificates will be issued with all addresses for the building listed on the certificate. Figure 3 is an example of a designation certificate for a four-unit townhouse.

Bulletin No. 2016-01

First Release:

March 4, 2016

Prepared by:

Remington Brown,
Senior Engineering Director

Applicable Standards:

- FORTIFIED Home™–Hurricane
- FORTIFIED Home™–High Wind
- FORTIFIED Home™–High Wind & Hail
- FORTIFIED for Safer Living®

Applicable Designation Level:



Figure 3. Example certificate for a qualified, four-unit townhouse.



Fastening Roof Sheathing Over Existing 1x Roof Deck Boards

Bulletin No. 2016-04

First Release:

November 2, 2016

Prepared by:

Laurie Jaworski,
FORTIFIED QA Manager

Mark Zehnal, Senior Roofing Specialist,
FORTIFIED Program Manager – Great Plains

Applicable Standards:

FORTIFIED Home™–High Wind
FORTIFIED Home™–High Wind & Hail
FORTIFIED for Safer Living®

Applicable Designation Level:



Abstract

FORTIFIED standards, asphalt shingle manufacturers and many municipalities require that shingles be installed over a solidly sheathed roof deck. Often, when re-roofing an existing home, a roof deck constructed with excessive spacing (more than $\frac{1}{8}$ in.) between boards is encountered. This bulletin provides information on how/when to install solid sheathing over spaced deck boards on homes located in areas that use the FORTIFIED Home™–High Wind and FORTIFIED Home™–High Wind & Hail standards.

Requirements

Maximum spacing of framing members (rafters or trusses) is 24 in. When unacceptably spaced boards exist where solid sheathing is required, there are three allowable options to achieve the FORTIFIED attachment of the new solid sheathing to the existing substrate.

Option 1

Remove existing boards and install sheathing ($\frac{7}{16}$ in. preferred) directly to the rafters/trusses per FORTIFIED requirements: 8d ring shank nails at 6 in. o.c. on all framing members.

Option 2

If the existing boards are in good condition, without cupping or rot present, install sheathing ($\frac{7}{16}$ in. preferred) over the existing boards by attaching the sheathing to the rafters/trusses below using minimum #8 deck screws, which must be long enough to penetrate into the wood framing members a minimum of $1\frac{1}{8}$ in.

Option 3

If the existing boards are in good condition, without cupping or rot present, install sheathing ($\frac{7}{16}$ in. preferred) over the existing boards by attaching the sheathing to the rafters/trusses below using minimum 0.120-in.-diameter ring-shank nails, which must



Roof Deck

be long enough to penetrate into the wood framing members a minimum of 1½ in.

Bulletin No. 2016-04

First Release:

November 2, 2016

Prepared by:

Laurie Jaworski,
FORTIFIED QA Manager

Mark Zehnal, Senior Roofing Specialist,
FORTIFIED Program Manager – Great Plains

Applicable Standards:

FORTIFIED Home™–High Wind
FORTIFIED Home™–High Wind & Hail
FORTIFIED for Safer Living®

Applicable Designation Level:



Minimum Fastener Lengths for Option 2 and Option 3

Sheathing Thickness	Nominal Board Thickness	Minimum Fastener Length (rounded up to nearest 1/8 in.)
7/16 in.	¾ in.	2 7/8 in.
7/16 in.	1 in.	3 1/8 in.
7/16 in.	1¼ in.	3 3/8 in.
7/16 in.	1½ in.	3 5/8 in.

Exception

In municipalities where the local code requirements exceed the FORTIFIED attachments, local code requirements shall have precedence. Always confirm that the roof deck construction meets the Building Department requirements.

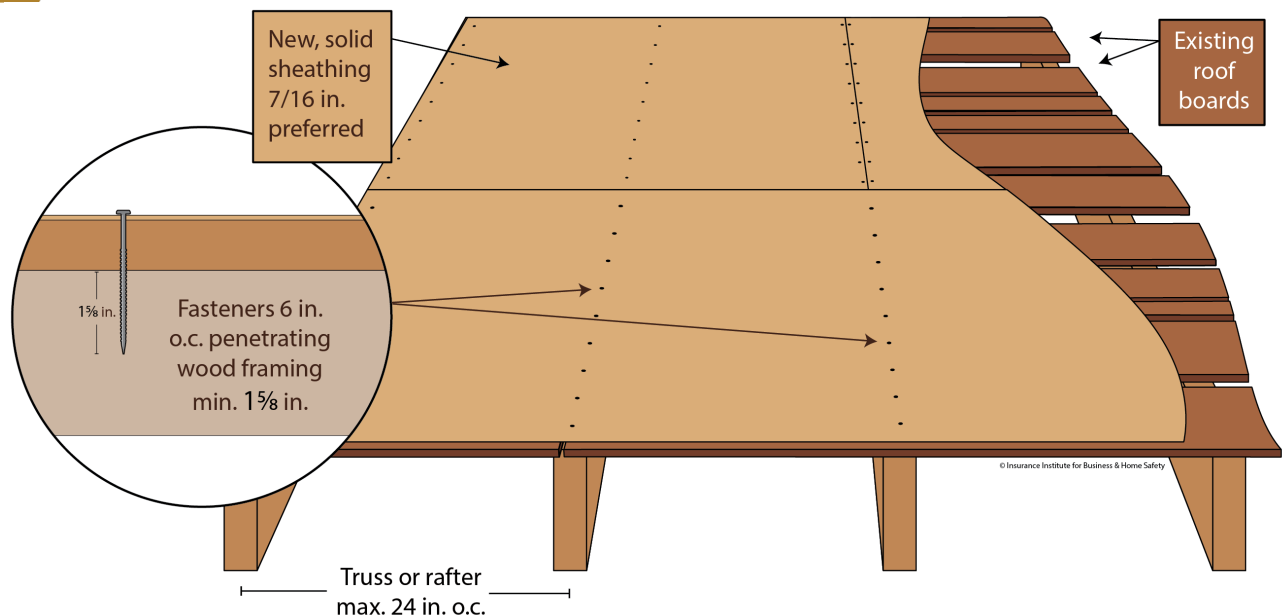



Roof Deck

Bulletin No. 2016-04

First Release:

November 2, 2016

Prepared by:

Laurie Jaworski,
FORTIFIED QA Manager

Mark Zehnal, Senior Roofing Specialist,
FORTIFIED Program Manager – Great Plains

Applicable Standards:

FORTIFIED Home™–High Wind
FORTIFIED Home™–High Wind & Hail
FORTIFIED for Safer Living®

Applicable Designation Level:



Documentation Requirements

The installation of the overlaid sheathing is to be documented and verified by a certified FORTIFIED Evaluator. Acceptable documentation includes but is not limited to a photo of the APA grading stamp to verify sheathing thickness, four separate photos showing fastener spacing delineated, photo of the fasteners illustrating length or of fastener carton label or copy of material supplier invoice recording fastener type/size delivered to the site, and a completed Roofing Compliance Form (RCF-1HWH).

For Evaluators Only: Evaluation Form Input

On the evaluation form, in section “Roof Deck,” for question “Roof Deck Type,” select “Deck over battens”. Next, indicate the sheathing thickness ($\frac{7}{16}$ in. min), fastener type and fastener size on the appropriate line followed by the fastener count in 48 in.

The screenshot shows a software interface for entering evaluation data. The 'Roof Deck' section is highlighted in green. The following fields are visible:

- Roof Pitch: >6/12
- Roof deck type: Deck over battens (indicated by a red arrow)
- Roof deck thickness: 7/16" (indicated by a red arrow)
- Roof deck fastener type: Ring shank nails (indicated by a red arrow)
- Roof deck fastener size: 10d nails (2-7/8 - 2-3/4 inches long) (indicated by a red arrow)
- Roof deck fastener count in 48" location 1: 0
- Roof deck fastener count in 48" location 2: 10
- Roof deck fastener count in 48" location 3: 10
- Roof deck fastener count in 48" location 4: 9
- Average number of missed fasteners: 1
- Is qualified supplemental deck attachment installed?: No

At the bottom, the 'Section: Roof Deck' is circled in red.



Bulletin No. 2016-05

First Release:

November 3, 2016

Prepared by:

Fred Malik, Vice President,
FORTIFIED Programs

Mark Zehnal, Senior Roofing Specialist,
FORTIFIED Program Manager – Great
Plains

Applicable Standards:

- FORTIFIED Commercial™–High Wind & Hail
- FORTIFIED Commercial™–Hurricane
- FORTIFIED Home™–High Wind
- FORTIFIED Home™–High Wind & Hail
- FORTIFIED Home™–Hurricane

Applicable Designation Level:



Asphalt Shingle Installation at Roof Edges, Intersections and Valleys

Abstract

This updated document is intended to provide additional guidance and options for asphalt shingle installations at roof edges, intersections and valleys. The verification and documentation requirement referenced in the original technical bulletin (Technical Bulletin 2016-05, released November 3, 2016) was effective December 5, 2016.

Introduction

Research conducted at the IBHS Research Center on a number of three-year-old roofs with various edge attachment details clearly demonstrated the need to ensure that shingles are properly installed and well adhered along the perimeter of a roof. While this directive has been included in standards and guidance since the beginning of the program, and also addressed in manufacturers’ high-wind guidance for asphalt shingle installation, it has not been specifically spotlighted in compliance forms or in evaluator training.

As a result, IBHS is issuing this updated technical bulletin to provide additional guidance with options that describe alternate methods to help ensure that asphalt shingles are well sealed and connected at roof edges, intersections and valleys. Please make sure you become familiar with the installation requirements outlined below and work with roofers to ensure proper installation instructions are followed. **Additionally, appropriate documentation described at the end of this bulletin continues to be required for all asphalt shingle roof installations.**



Bulletin No. 2016-05

First Release:

November 3, 2016

Prepared by:

Fred Malik, Vice President,
FORTIFIED Programs

Mark Zehnal, Senior Roofing Specialist,
FORTIFIED Program Manager – Great Plains

Applicable Standards:

- FORTIFIED Commercial™–High Wind & Hail
- FORTIFIED Commercial™–Hurricane
- FORTIFIED Home™–High Wind
- FORTIFIED Home™–High Wind & Hail
- FORTIFIED Home™–Hurricane

Applicable Designation Level:



Sealed Roof Deck Installation Options

Taped Sheathing Seams

Tape Installation

Tape must be rolled to help ensure it is installed flat and adheres to the deck. If the tape doesn't stick well, the seams must be primed or a different product that does stick well must be used. Recent IBHS experience suggests that there may be fewer adhesion problems for installations on OSB decks with the high temperature-rated acrylic tape allowed by the program.

Underlayment Installation

Apply a code-compliant ASTM D226, Type II underlayment over the self-adhering tape (felt or synthetic is allowed). This underlayment shall be attached using annular ring or deformed shank roofing fasteners with minimum 1-in.-diameter caps at 6 in. o.c. spacing along all laps and two rows 12 in. o.c. in the field or a more stringent fastener schedule if required by the manufacturer for high-wind installations. Horizontal laps shall be a minimum of 2 in. and end laps shall be a minimum of 6 in. Nails with plastic or metal caps are allowed in areas where the design wind speed is less than 140 mph. Metal caps are required for areas where the design wind speed is greater than or equal to 140 mph.

ASTM D1970 Self-Adhered Membranes

ASTM D1970 Membrane Installation

Cover the entire roof with a full layer of self-adhering polymer-modified bitumen membrane meeting ASTM D1970 requirements.

Recommended Bond Break Installation

It is recommended that #15 felt be installed over the membrane to provide a bond break between the self-adhering membrane and the shingles in order to prevent the shingles from fusing with the self-adhering membrane. The bond break shall be held back 8 in. from the eave and rake edges to allow application of flashing cement along the edges to ensure proper sealing of shingles along the roof edges.



Roof Edges, Intersections and Valleys

Bulletin No. 2016-05

First Release:

November 3, 2016

Prepared by:

Fred Malik, Vice President,
FORTIFIED Programs

Mark Zehnal, Senior Roofing Specialist,
FORTIFIED Program Manager – Great
Plains

Applicable Standards:

- FORTIFIED Commercial™–High Wind & Hail
- FORTIFIED Commercial™–Hurricane
- FORTIFIED Home™–High Wind
- FORTIFIED Home™–High Wind & Hail
- FORTIFIED Home™–Hurricane

Applicable Designation Level:



Drip Edge Installation Requirements

1. Provide code-compliant, minimum gauge metal drip edge at eaves and gables.
2. Overlap to be a minimum of 3 in. at joints.
3. Eave drip edges shall extend ½ in. below sheathing and extend back on the roof a minimum of 2 in.
4. The drip edge shall be mechanically fastened to the roof deck. Fasteners shall be fabricated from similar or compatible material. For FORTIFIED–Hurricane compliance, spacing shall be a maximum of 4 in. o.c. For FORTIFIED–High Wind and FORTIFIED–High Wind & Hail compliance, spacing shall be a maximum of 12 in. o.c. Mechanical fasteners shall be applied in an alternating (staggered) pattern along the length of the drip edge with adjacent fasteners placed near opposite edges of the leg/flange of drip edge on the roof.
5. Drip edge at eaves shall be installed over the underlayment (this is compatible with high-wind installations where flashing cement is used to seal the edges).

Installation of Starter Strips at Eaves (Drip Edge Installed Over Underlayment)

Manufacturer-approved starter strips at eaves shall be set in a minimum 8-in.-wide strip of compatible flashing cement. Maximum thickness of flashing cement shall be ⅛ in. Fasten starter strips parallel to the eaves along a line above the eave line according to the manufacturer’s specifications. Position fasteners to ensure they will not be exposed under the cutouts in the first course. Starter strips and shingles must not extend more than ¼ in. beyond the drip edge.

Approved Option

Shingle manufacturer–approved ASTM D1970 fully adhered (peel-and-stick) starter strip with asphaltic adhesive strip at eave— installed so that starter strip adheres to and covers the drip edge top surface.



Shingle Installation at Roof Edge

Bulletin No. 2016-05

First Release:

November 3, 2016

Prepared by:

Fred Malik, Vice President,
FORTIFIED Programs

Mark Zehnal, Senior Roofing Specialist,
FORTIFIED Program Manager – Great
Plains

Applicable Standards:

FORTIFIED Commercial™–High Wind &
Hail

FORTIFIED Commercial™–Hurricane

FORTIFIED Home™–High Wind

FORTIFIED Home™–High Wind & Hail

FORTIFIED Home™–Hurricane

Applicable Designation Level:



Installation of Shingles at Rakes (Drip Edge Installed Over Underlayment)

Install shingles at rakes set in a minimum 8-in.-wide strip of compatible flashing cement. Maximum thickness of flashing cement shall be $\frac{1}{8}$ in. Fasten shingles at the rakes according to the manufacturer's specifications.

Optional Installation of Starter Strips at Rakes (Drip Edge Installed Over Underlayment)

Manufacturer-approved starter strips at rakes shall be set in a minimum 8-in.-wide strip of compatible flashing cement. Maximum thickness of flashing cement shall be $\frac{1}{8}$ in. Fasten starter strips parallel to the rakes according to the manufacturer's specifications. Position fasteners to ensure they will not be exposed. Starter strips and shingles must not extend more than $\frac{1}{4}$ in. beyond the drip edge.

Approved Option

Shingle manufacturer–approved ASTM D1970 fully adhered (peel-and-stick) starter strip with asphaltic adhesive strip at rake—installed so that starter strip adheres to and covers the drip edge top surface.

Attachment of Shingles at Intersections and Valley

Shingles installed at all intersections and both sides of open valleys shall be set in a minimum 8-in.-wide strip of flashing cement. Maximum thickness of flashing cement shall be $\frac{1}{8}$ in. Cut side of closed valleys shall be set in a minimum 2-in.-wide, $\frac{1}{8}$ -in.-thick strip of flashing cement. Woven valleys to be according to the manufacturer's specifications.



Bulletin No. 2016-05

First Release:

November 3, 2016

Prepared by:

Fred Malik, Vice President,
FORTIFIED Programs

Mark Zehnal, Senior Roofing Specialist,
FORTIFIED Program Manager – Great
Plains

Applicable Standards:

- FORTIFIED Commercial™–High Wind & Hail
- FORTIFIED Commercial™–Hurricane
- FORTIFIED Home™–High Wind
- FORTIFIED Home™–High Wind & Hail
- FORTIFIED Home™–Hurricane

Applicable Designation Level:



Verification and Documentation

The contractor shall complete the revised compliance form and provide in-progress photos with identifiable traits or landmarks of the property showing the following:

1. Installation of tape or self-adhered membrane.
2. Fastening of underlayment.
3. Fastening of drip edge metal over underlayment.
4. Application of flashing cement or approved alternate means of attachment along roof edges, intersections and valleys.
5. Installation of approved starter strips at eaves.

The Evaluator shall verify that shingles along the edges of the roof do not overhang more than ¼ in. beyond the drip edge metal.



Roof Flashing

Bulletin No. 2017-01

First Release:

January 6, 2017

Prepared by:

Remington Brown,
Senior Engineering Director

Applicable Standards:

- FORTIFIED Home™–Hurricane
- FORTIFIED Home™–High Wind
- FORTIFIED Home™–High Wind & Hail
- FORTIFIED for Safer Living®

Applicable Designation Level:



Abstract

Roof flashing is an integral component of the roof system. It is used to seal roof systems where the system is interrupted or terminated and is **always** required when installing a new roof or re-roofing an existing home. Examples of roof flashing include: drip edge at the eave and rake, valley flashing, wall and chimney flashing, flashing at roof pitch changes, and flashing at all roof penetrations. This bulletin instructs installers that all flashing installed on a FORTIFIED roof must be in **new condition** and points to roof covering manufacturers for flashing installation instructions.

Requirements

When re-roofing an existing home or installing a roof on a new home, all installed flashing shall be new material. When re-roofing, all existing flashing material shall be removed and discarded. New flashing shall be properly installed in accordance with the roof manufacturer’s installation instructions and in compliance with all applicable building codes.

FORTIFIED has specific requirements for asphalt shingle drip edge flashing installation and attachment that may go beyond roof manufacturers’ flashing installation instruction and/or typical building code requirements. New drip edge metal must be installed at the eaves and the gable rakes.

Documentation Requirements

The installation of **new** roof flashing is to be verified by a certified FORTIFIED Evaluator through observation and photographs.



Bulletin No. 2017-04

First Release:

December 12, 2017

Prepared by:

Fred Malik, Vice President,
FORTIFIED Programs

Applicable Standards:

FORTIFIED Home™—Hurricane
FORTIFIED Home™—High Wind
FORTIFIED Home™—High Wind & Hail
FORTIFIED for Safer Living™

Applicable Designation Level:



Eligibility Requirements and Retrofit Requirements for Elevated-Floor (Not Slab-on-Grade) Houses

Applicable Conditions

1. Dry stack foundations: all house types
2. All elevated-floor home-to-foundation connections

Abstract

This technical bulletin is intended to clarify FORTIFIED Home™ requirements that relate to a home’s foundation and the need for the home to have a positive connection to the foundation in order to be eligible for a FORTIFIED Home designation. The criteria included are requirements for any and all FORTIFIED Home designations and are not limited to FORTIFIED Home Gold designations which address the continuous load path.

Requirements

Dry Stack Foundations

A dry stack foundation is defined as a foundation constructed of unrestrained stacked masonry or stone.

Eligibility: Homes that are supported by a dry stack foundation are ineligible for any level of FORTIFIED Home designation unless the home is retrofitted so that it is supported by and attached to a permanent foundation capable of resisting the design level wind uplift and lateral forces on the building.

All Foundations

To be eligible for designation or re-designation under the FORTIFIED Home program, homes with elevated floors (not slab-on-grade construction) must have adequate positive connections from the floor or wall structure to the supporting foundation, e.g. homes on piers or pilings must have a connection from the



Eligibility Requirements—Foundations

Bulletin No. 2017-04

First Release:

December 12, 2017

Prepared by:

Fred Malik, Vice President,
FORTIFIED Programs

Applicable Standards:

FORTIFIED Home™—Hurricane
FORTIFIED Home™—High Wind
FORTIFIED Home™—High Wind & Hail
FORTIFIED for Safer Living™

Applicable Designation Level:



piers/pilings to the perimeter beams of the house. All connectors must be free from damage, corrosion-resistant (if applicable) in accordance with Appendix D of the FORTIFIED Home—Hurricane standards, and installed per the connector manufacturer’s installation instructions.

HUD-Code Manufactured Home Foundations

Foundation must meet the design wind load requirements with no more than ¼-in. lateral deflection. Requirements specified in the U.S. Department of Housing and Urban Development (HUD) Permanent Foundation Guide for Manufactured Housing (HUD-4930.3G) dated September 1996 or later provide useful assistance in identifying suitable foundation options. Based on results of past inspections of home installations that were reported as permanent, the following requirements of the HUD Guide and FORTIFIED Home requirements are emphasized and are part of the Field Evaluation inspection.

1. Screw-in soil anchors are not considered a permanent anchorage and cannot be used as any part of the required permanent foundation unless their heads are restrained from lateral movement by embedment in a reinforced concrete footing or concrete slab.
2. All concrete masonry unit (CMU) bearing walls, piers and columns, as well as any units used as part of systems to resist uplift, overturning and lateral loads must be composed of reinforced concrete masonry with mortared bed and head joints. Cells with reinforcing must be fully grouted. Dry-stacking of CMU is not allowed.
3. All bearing walls, piers and columns must be installed on and connected to acceptable footings or a concrete slab. Footings and slabs must be protected from the effects of frost heave by extending below the frost line or by using a frost protected shallow foundation design.
4. Walls and piers used as part of the uplift, overturning or lateral load-resisting system must include adequately sized connections and elements capable of resisting tension or compression loads as appropriate. Straps or cables are acceptable, provided they are connected to the home or its chassis and transfer the design loads to the slab or footings supporting the walls, piers or columns. Use



Eligibility Requirements—Foundations

Bulletin No. 2017-04

First Release:

December 12, 2017

Prepared by:

Fred Malik, Vice President,
FORTIFIED Programs

Applicable Standards:

FORTIFIED Home™—Hurricane
FORTIFIED Home™—High Wind
FORTIFIED Home™—High Wind & Hail
FORTIFIED for Safer Living™

Applicable Designation Level:



of frictional resistance between the home or its chassis and the tops of the walls, piers or columns or between the bottom of the walls, piers or columns and the footings to resist lateral loads is not allowed.

Eligibility: Manufactured homes must be installed on a foundation designed and installed in accordance with the criteria outlined above. A certification attesting to compliance with the design requirements of the HUD Permanent Foundations Guide for Manufactured Housing (HUD-4930.3G) dated September 1996 or later, and the requirements outlined above must be provided by a licensed professional engineer or registered architect. A copy of the certification and foundation design must be provided before or during the Field Evaluation at the time of the house setting for reference by the inspector and submission to IBHS.

Documentation Requirements

A minimum of four (4) photographs of a home’s foundation is required. The photographs must be taken from four different locations around the perimeter of the home.

Photographs of connectors are required. If any damaged or corroded connectors are present, photographs of the damaged connector(s) need to be provided in the “General/Site Information” section of the evaluation form regardless of designation level being sought. Photographs can be added to the **Finished Elevation Photos** portion of the form.

For Evaluators Only: Evaluation Form Input

Photographs of the foundation and connectors from perimeter beam to foundation need to be uploaded in the “General/Site Information” section of the evaluation form regardless of designation level being sought. Photographs can be added to the **Finished Elevation Photos** portion of the form.